

CATALOGO TRINCIATRICI & TOSAERBA



GEO[®]
Macchine Agricole



www.geo-agric.com



info@geo-agric.com



Tel. +39 0141877368 1



Our Different Idea...



GARANZIA 2 ANNI.

Per ulteriori dettagli visitate il nostro sito web: www.geo-agric.com

Caratteristiche tecniche e foto sono fornite a titolo indicativo, ed in nessun caso avranno valore contrattuale.

La società GEO ITALY si riserva il diritto di apportare ai propri prodotti modifiche e migliorie ritenute necessarie senza preavviso. In materia di sicurezza, GEO ITALY raccomanda agli utenti di consultare le istruzioni d'uso fornite assieme ai prodotti.



www.geo-agric.com



info@geo-agric.com



Tel. +39 0141877368



Azienda

GEO è un'azienda italiana specialista nella fornitura di attrezzature e accessori per la manutenzione del verde e cura del terreno. In pochi anni grazie alla sua vasta gamma di prodotti ha saputo ritagliarsi un'importante fetta di mercato, proponendo il miglior rapporto qualità prezzo su territorio Europeo.

Attualmente GEO conta più di 500 rivenditori autorizzati sui principali mercati europei.





INDICE

pg. 08



Trinciatrici fisse

EFM	EFGC OT
EFG	DPS
EFGC	DPS 220

pg. 20



Trinciatrici con spostamento idraulico

EFGCH	MA
DP	DISK MA
DP 220	GKK

pg. 34



Trinciatrici con raccoglitore

FL
FLP

pg. 38



Trinciatrici reversibili

DPG
AGN

pg. 42



Trinciatrici laterali

AGS	AGE	AGFN
AGL	AGD	
AGL-C	AGF	

pg. 56



Trinciatrici a braccio

AM	AMD
AMD	AM-T
BRC	BJ

pg. 68



Piattaforma tosaerba

KM100	DM 210-N
TM	DM3 210
DM SILVER	

pg. 78



Piattaforma tosaerba con disco

DISK	GBDD 120
GB	GBDD 150-180
GBH	



EFM



EFG



EFGC



EFGC OT



DPS



DPS 220



EFGCH



EFGCH OT



DP



DP 220



MA



MA DISK



GKK



AGS



AGL



AGL-C



AGE



AGD



AGF



AGFN



FL



FLP



DPG



AGN



AM



AM 125



AMD



BRC



AM-T



BJ



KM100



TM



DM SILVER



DM 210N



DM3 210



DISK



GB



GBH



GB 120 DD



GB 150/190 DD

EFM

TRINCIATRICE LEGGERA CON TERZO PUNTO REGOLABILE



 **15-35HP**





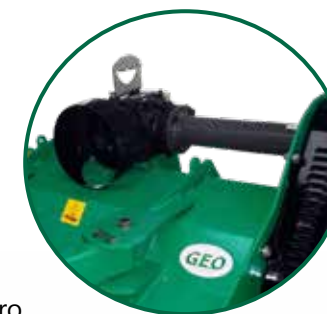

- Scatola ingranaggi in ghisa con ruota libera integrata
- Lubrificazione scatola ingranaggi: olio SAE 90
- Potenza di trasmissione applicabile: 35 HP
- Rullo posteriore registrabile in altezza
- Tenditore cinghie regolabile
- Spessore fiancate laterali: 6 mm
- Slitte laterali registrabili
- Rotore con sistema di taglio lineare
- Piedino di appoggio
- Spostamento laterale meccanico con 5 posizioni di lavoro

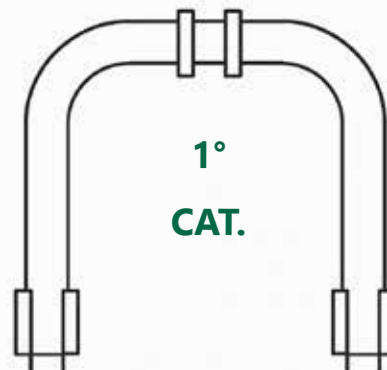

 Ø: 1-2 cm

ATTACCO TERZO PUNTO



UTENSILI					
 		 			
A	R	(gr)	A	R	(gr)
40	80	150	80	80	300

ØA	305 mm	ØB	90 mm	ØC	90 mm
----	--------	----	-------	----	-------

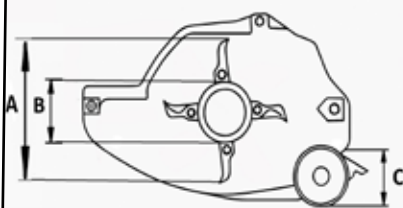

RPM: 540

L= EFM 115: T-4x1000
 L= EFM 125: T-4x1000
 L= EFM 145: T-4x1000
 L= EFM 155: T-4x1000



HPTO: 45 cm
 h1: 33 cm

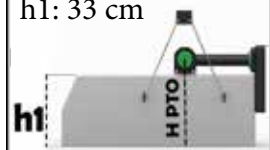

Area di lavoro (cm)	EFM 115		EFM 125		EFM 145		EFM 155	
	Left	Right	Left	Right	Left	Right	Left	Right
EFM 115	65	50	50	65	35	80		
EFM 125	70	55	55	70	40	85		
EFM 145	80	65	65	80	50	95		
EFM 155	85	70	70	85	55	100		

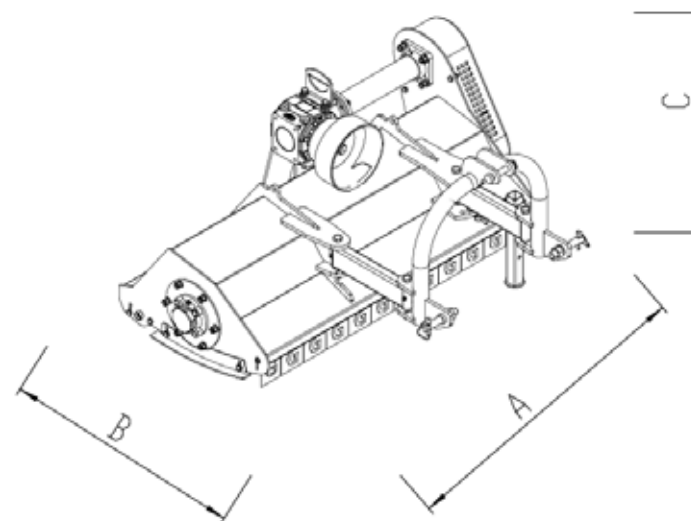

Mod.	Cod.	Larghezza di lavoro (cm)	A (Cm)	B (cm)	C (cm)	HP/Kw	Kg	Cinghie	Martelli	Coltelli
EFM 115	3.71.115	115	134	104	72	15-35 / 12-26	151	2	36	18
EFM 125	3.71.125	125	154	104	72	15-35 / 12-26	156	2	18	18
EFM 145	3.71.145	145	164	104	72	20-35 / 16-26	167	3	40	20
EFM 155	3.71.155	155	174	104	72	20-35 / 16-26	173	3	48	24

EFG

TRINCIATRICE LEGGERA FISSA









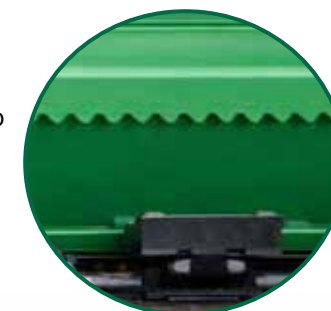

 15-40HP



- Scatola ingranaggi in ghisa con ruota libera integrata
- Lubrificazione scatola ingranaggi: olio SAE 90
- Potenza di trasmissione applicabile: 35 HP
- Rullo posteriore registrabile in altezza con raschia fango
- Tenditore cinghie regolabile
- Controcoltello dentato
- Spessore fiancate laterali: 6 mm
- Slitte laterali registrabili
- Rotore con sistema di taglio lineare
- Piedino di appoggio



 Ø: 2-3 cm

UTENSILI					
  		  			
A (mm)	R (mm)		A (mm)	R (mm)	
50	80	150	80	80	400

ATTACCO TERZO PUNTO

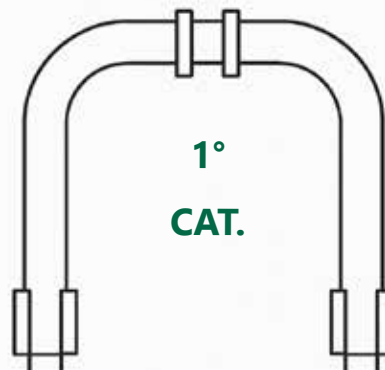

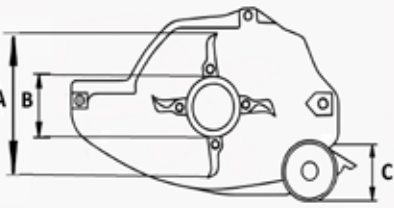
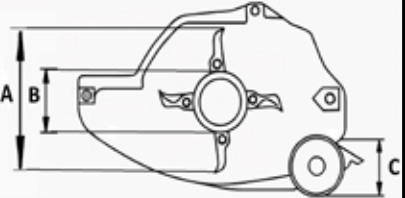
$\varnothing A$ 325 mm	$\varnothing B$ 110 mm	$\varnothing C$ 100 mm	 <p>RPM: 540</p>
 <p>L= EFG 115: T-4x800 L= EFG 125: T-4x800 L= EFG 145: T-4x800 L= EFG 155: T-4x800 L= EFG 165: T-5X800 L= EFG 175: T-5X800</p>			

HPTO: 45 cm
h1: 37 cm

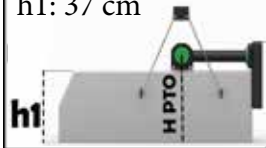

Area di lavoro (cm)		
EFG 105	50	55
EFG 115	50	65
EFG 125	60	65
EFG 145	60	85
EFG 155	70	85
EFG 165	70	95
EFG 175	70	105

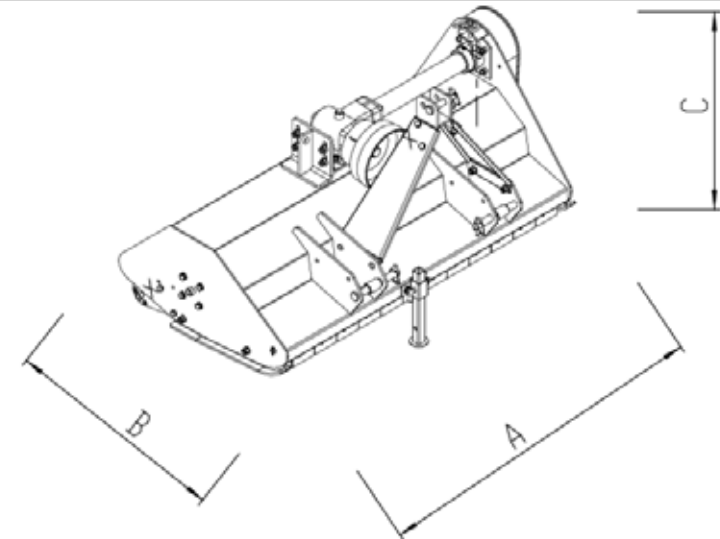

Mod.	Cod.	Larghezza di lavoro (cm)	A (cm)	B (cm)	C (cm)	HP/kW	Kg	Cinghie	Coltelli	Martelli
EFG 105	3.23.105	105	118	79	78	15-35 / 12-26	156	2	36	18
EFG 115	3.24.115	115	128	79	78	15-35 / 12-26	178	2	40	20
EFG 125	3.18.125	125	138	79	78	20-35 / 15-26	190	2	42	21
EFG 145	3.19.145	145	160	79	78	25-35 / 18-26	210	3	48	24
EFG 155	3.20.155	155	170	79	78	30-40 / 22-30	240	3	54	27
EFG 165	3.21.165	165	180	79	78	30-40 / 22-30	275	3	54	27
EFG 175	3.22.175	175	190	79	78	30-40 / 22-30	285	4	60	30

EFGC

TRINCIATRICE LEGGERA FISSA



 **20-60 HP**



- Scatola ingranaggi in ghisa con ruota libera integrata
- Lubrificazione scatola ingranaggi: olio SAE 90
- Potenza di trasmissione applicabile: 50 HP
- Rullo posteriore registrabile in altezza con raschia fango
- Tenditore cinghie regolabile
- Controcoltello dentato
- Spessore fiancate laterali: 6 mm
- Slitte laterali registrabili
- Rotore con sistema di taglio lineare

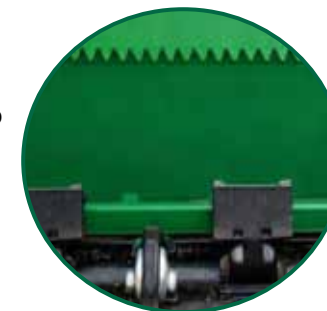

 **Ø: 3-4 cm**

UTENSILI					
					
A		R		R	
A (mm)	R (mm)		A (mm)	R (mm)	
50	110	300 (gr)	90	95	600 (gr)

ATTACCO TERZO PUNTO

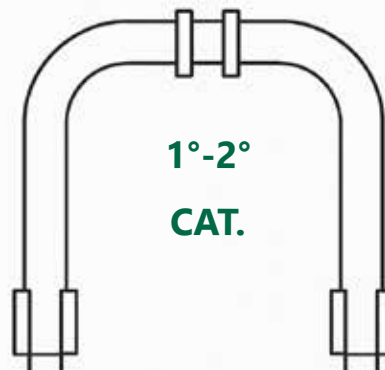

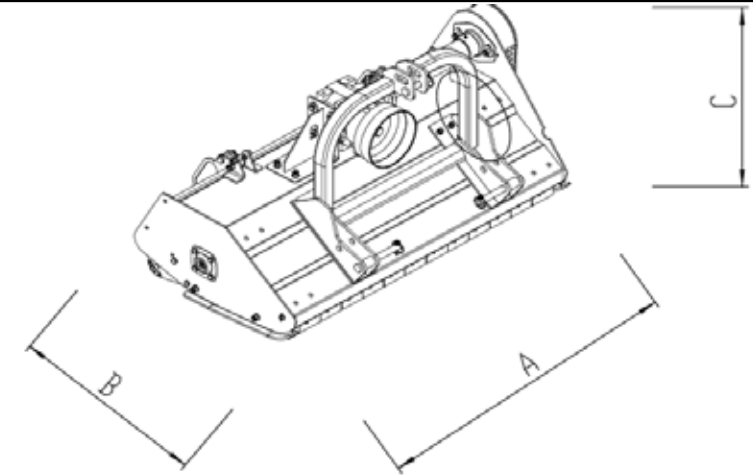
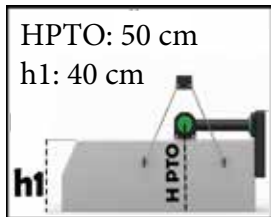
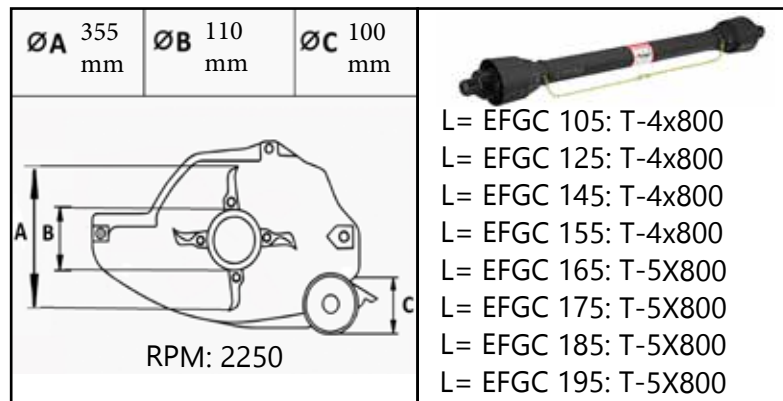

Area di lavoro (cm)		
EFGC 105	52	53
EFGC 125	61	64
EFGC 145	61	84
EFGC 155	61	94
EFGC 165	61	104
EFGC 175	61	114
EFGC 185	61	124
EFGC 195	61	134

Mod.	Cod.	Larghezza di lavoro (cm)	A (cm)	B (cm)	C (cm)	HP/kW	Kg	Cinghie	Coltelli	Martelli
EFGC 105	3.24.105	105	118	79	83	20-35 / 16-26	196	2	32	16
EFGC 125	3.25.125	125	138	79	83	25-40 / 18-29	225	2	40	20
EFGC 145	3.26.145	145	160	79	83	25-40 / 18-29	255	3	48	24
EFGC 155	3.27.155	155	170	79	83	30-50 / 22-37	270	3	48	24
EFGC 165	3.28.165	165	180	79	83	40-60 / 30-44	285	3	56	28
EFGC 175	3.29.175	175	192	79	83	40-60 / 30-44	300	4	56	28
EFGC 185	3.28.185	185	202	79	83	40-60 / 30-44	320	4	64	32
EFGC 195	3.29.195	195	212	79	83	40-60 / 30-44	325	4	64	32

EFGC OT

TRINCIATRICE FISSA CON COFANO APRIBILE



 25-60 HP



- Scatola ingranaggi in ghisa con ruota libera integrata
- Lubrificazione scatola ingranaggi: olio SAE 90
- Potenza di trasmissione applicabile: 50 HP
- Rullo posteriore registrabile in altezza con raschia fango
- Tenditore cinghie regolabile
- Controcoltello dentato
- Spessore fiancate laterali: 6 mm
- Slitte laterali registrabili
- Rotore con sistema di taglio lineare
- Cofano apribile per facilitare le operazioni di manutenzione

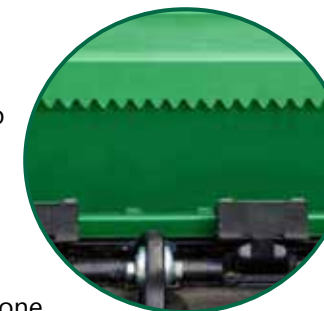

 Ø: 3-4 cm

UTENSILI					
					
A		R		A	
A (mm)	R (mm)		A (mm)	R (mm)	
50	110	300 (gr)	90	95	600 (gr)

ATTACCO TERZO PUNTO

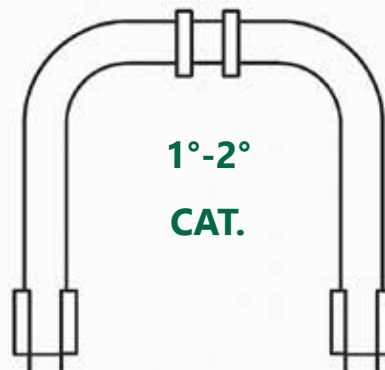

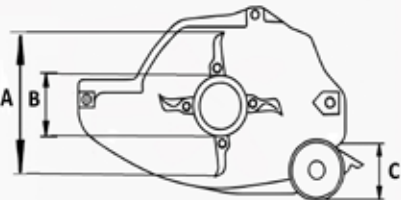

$\varnothing A$ 355 mm	$\varnothing B$ 110 mm	$\varnothing C$ 100 mm	 <p>L= EFGC 125 OT: T-4x800 L= EFGC 145 OT: T-4x800 L= EFGC 155 OT: T-4x800 L= EFGC 165 OT: T-5X800 L= EFGC 175 OT: T-5X800 L= EFGC 185 OT: T-5X800 L= EFGC 195 OT: T-5X800</p>
 <p>RPM: 2250</p>			

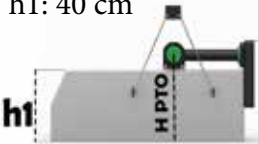

HPTO: 50 cm
h1: 40 cm



Area di lavoro (cm)		
EFGC 125 OT	61	64
EFGC 145 OT	61	84
EFGC 155 OT	61	94
EFGC 165 OT	61	104
EFGC 175 OT	61	114
EFGC 185 OT	61	124
EFGC 195 OT	61	134

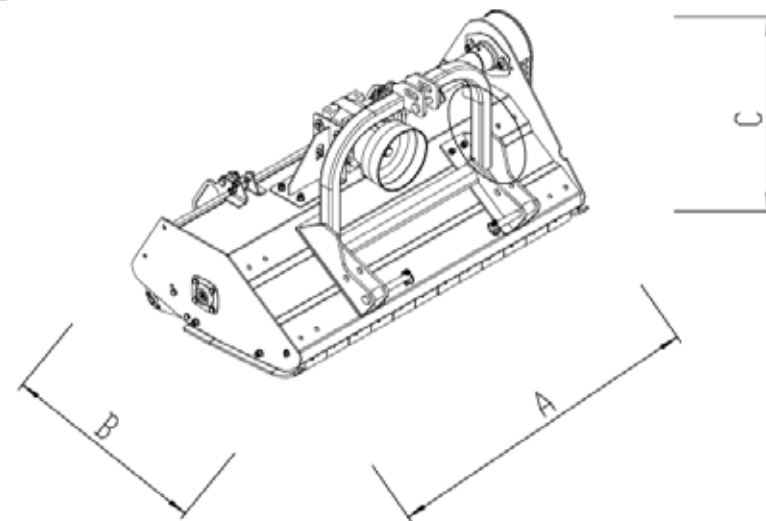

Mod.	Cod.	Larghezza di lavoro (cm)	A (cm)	B (cm)	C (cm)	HP/kW	Kg	Cinghie	Coltelli	Martelli
EFGC 125 OT	3.44.105	125	138	79	83	20-35 / 16-26	225	2	32	20
EFGC 145 OT	3.44.145	145	160	79	83	25-40 / 18-29	255	3	48	24
EFGC 155 OT	3.44.155	155	170	79	83	25-40 / 18-29	270	3	48	24
EFGC 165 OT	3.44.165	165	180	79	83	30-50 / 22-37	285	3	56	28
EFGC 175 OT	3.44.175	175	192	79	83	40-60 / 30-44	300	4	56	28
EFGC 185 OT	3.44.185	185	202	79	83	40-60 / 30-44	320	4	64	32
EFGC 195 OT	3.44.195	195	212	79	83	40-60 / 30-44	325	4	64	32

DPS

TRINCIATRICE CON SCARICO POSTERIORE AL RULLO



 40-70 HP



- Scatola ingranaggi in ghisa con ruota libera integrata
- Lubrificazione scatola ingranaggi: olio SAE 90
- Potenza di trasmissione applicabile: 50 HP
- Rullo posteriore registrabile in altezza con raschia fango
- Tenditore cinghie regolabile
- Controcoltello dentato
- Spessore fiancate laterali: 8 mm
- Slitte laterali registrabili
- Rotore con sistema di taglio lineare
- Scarico posteriore al rullo
- Piedino di appoggio
- Protezione anteriore a catene

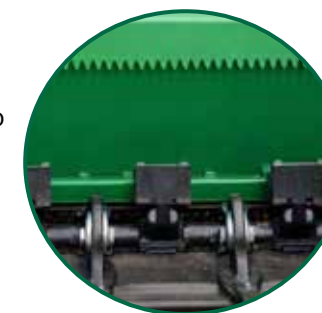



 Ø: 3-5 cm

UTENSILI					
					
A		R		R	
A (mm)	R (mm)		A (mm)	R (mm)	
50	110	300 (gr)	90	95	600 (gr)

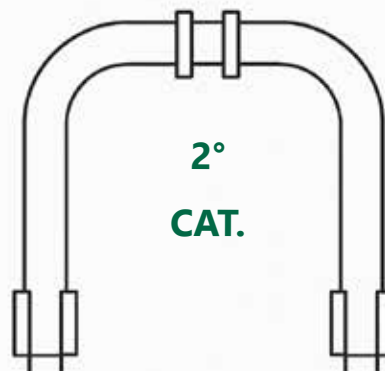
ATTACCO TERZO PUNTO

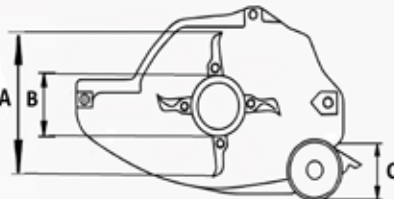

Scarico posteriore al rullo

$\varnothing A$ 355 mm	$\varnothing B$ 110 mm	$\varnothing C$ 150 mm	
			



RPM: 2250

L= DPS 125: T-4x1000
 L= DPS 155: T-5x1000
 L= DPS 165: T-5x1000
 L= DPS 175: T-5x1000
 L= DPS 185: T-5x1000
 L= DPS 195: T-5x1000
 L= DPS 205: T-6x1000

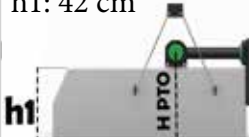

HPTO: 45 cm
 h1: 42 cm



Area di lavoro (cm)		
DPS 125	60	65
DPS 155	72	83
DPS 165	72	93
DPS 175	72	103
DPS 185	72	113
DPS 195	87	108
DPS 205	87	118

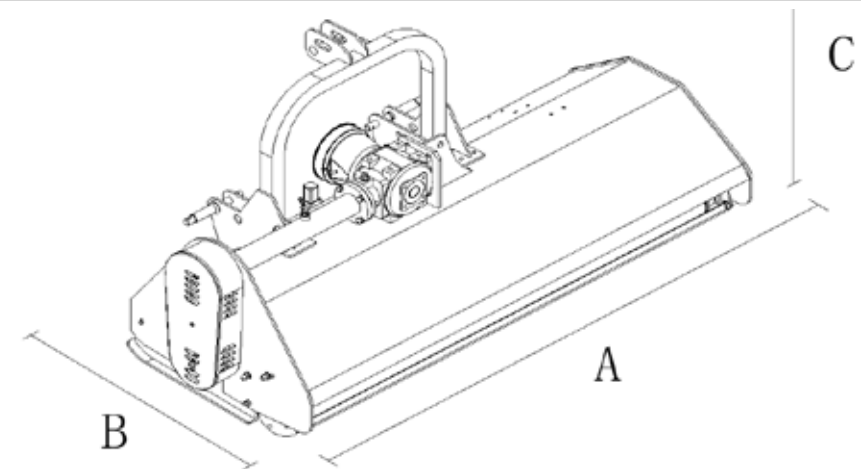

Mod.	Cod.	Larghezza di lavoro (cm)	A (cm)	B (cm)	C (cm)	HP/kW	Kg	Cinghie	Coltelli	Martelli
DPS 125	3.90.125	125	140	77	96	40-65 / 30-48	270	4	40	20
DPS 155	3.90.155	155	170	77	96	40-65 / 30-48	300	4	48	24
DPS 165	3.90.165	165	180	77	96	40-65 / 30-48	315	4	56	28
DPS 175	3.90.175	175	190	77	96	60-70 / 45-52	330	4	56	28
DPS 185	3.90.185	185	200	77	96	60-70 / 45-52	345	4	64	32
DPS 195	3.90.195	195	210	77	96	60-70 / 45-52	350	4	64	32
DPS 205	3.90.205	205	220	77	96	60-70 / 45-52	355	4	64	32

DPS 220

TRINCIATRICE CON SCARICO POSTERIORE AL RULLO



 **40-70 HP**



- Scatola ingranaggi in ghisa con ruota libera integrata
- Lubrificazione scatola ingranaggi: olio SAE 90
- Potenza di trasmissione applicabile: 50 HP
- Rullo posteriore registrabile in altezza con raschia fango
- Tenditore cinghie regolabile
- Controcoltello dentato
- Spessore fiancate laterali: 8 mm
- Slitte laterali registrabili
- Rotore con sistema di taglio lineare
- Scarico posteriore al rullo
- Scocca rinforzata maggiorata
- Piedino di appoggio
- Protezione anteriore a catene



 **Ø: 3-5 cm**

UTENSILI					
					
A		R		A	
A (mm)	R (mm)		A (mm)	R (mm)	
50	110	300	90	95	600

ATTACCO TERZO PUNTO

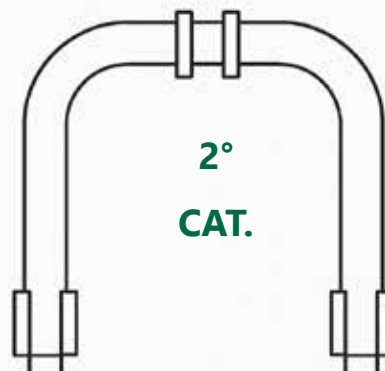

Scarico posteriore al rullo

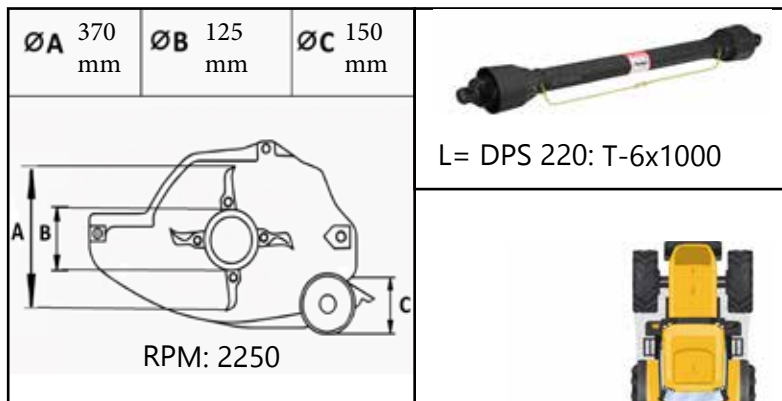

L= DPS 220: T-6x1000

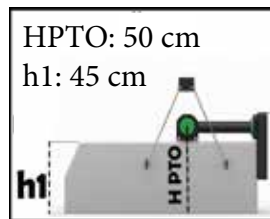

Area di lavoro (cm)		
DPS 220	99	121

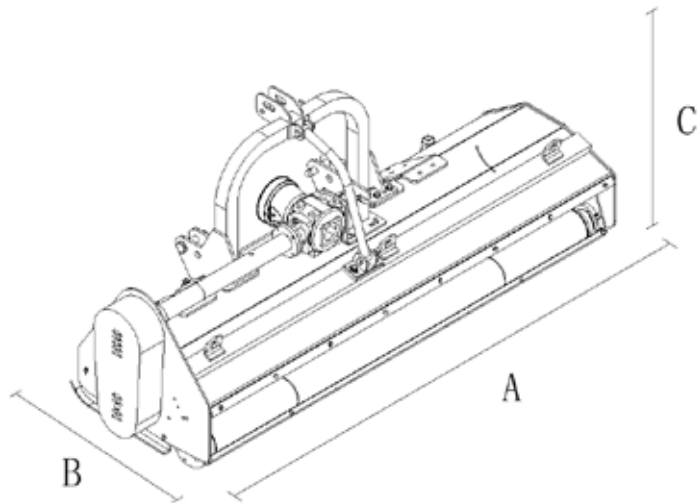

Mod.	Cod.	Larghezza di lavoro (cm)	A (cm)	B (cm)	C (cm)	HP/kW	Kg	Cinghie	Coltelli	Martelli
DPS 220	3.90.220	220	237	78	99	60-70 / 45-52	501	4	68	34

EFGCH

TRINCIATRICE CON SPOSTAMENTO IDRAULICO

 25-60 HP



- Scatola ingranaggi in ghisa con ruota libera integrata
- Lubrificazione scatola ingranaggi: olio SAE 90
- Potenza di trasmissione applicabile: 50 HP
- Rullo posteriore registrabile in altezza con raschia fango
- Tenditore cinghie regolabile
- Controcoltello dentato
- Spessore fiancate laterali: 6 mm
- Slitte laterali registrabili
- Rotore con sistema di taglio lineare
- Spostamento laterale idraulico: 360 mm



 Ø: 3-4 cm

UTENSILI					
					
A		R		R	
A (mm)	R (mm)		A (mm)	R (mm)	
50	110	300	90	95	600

ATTACCO TERZO PUNTO

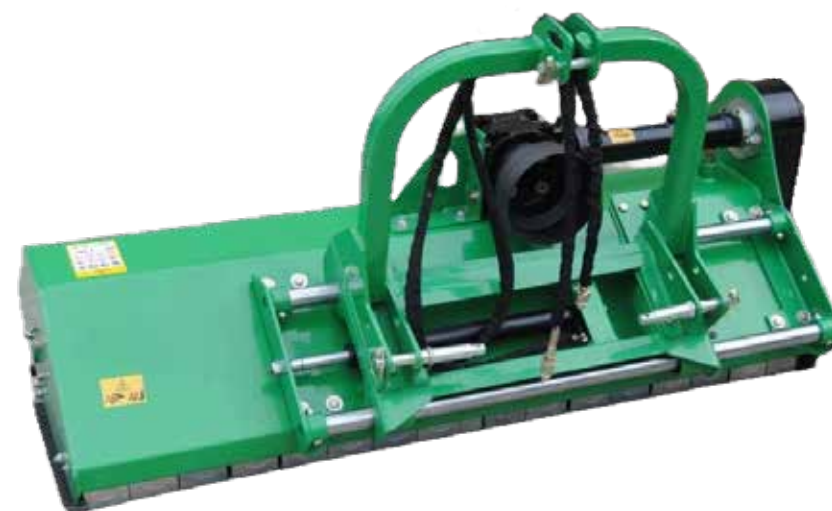
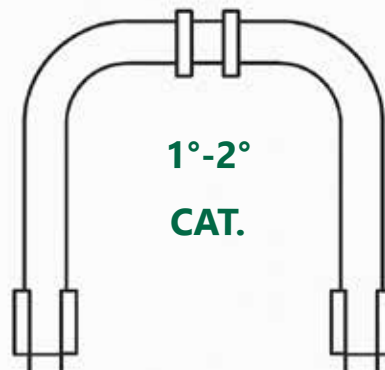

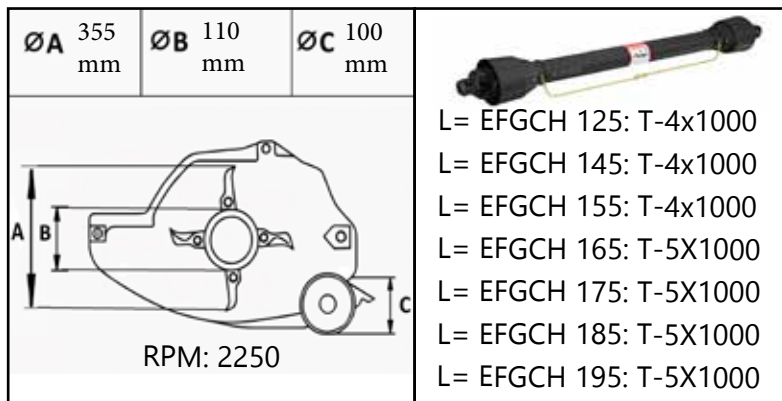

- L= EFGCH 125: T-4x1000
- L= EFGCH 145: T-4x1000
- L= EFGCH 155: T-4x1000
- L= EFGCH 165: T-5X1000
- L= EFGCH 175: T-5X1000
- L= EFGCH 185: T-5X1000
- L= EFGCH 195: T-5X1000

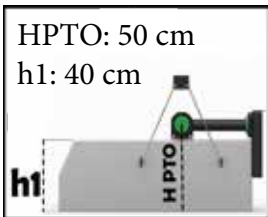

Area di lavoro (cm)				
EFGCH 125	80	45	44	81
EFGCH 145	80	65	44	101
EFGCH 155	80	75	44	111
EFGCH 165	80	85	44	121
EFGCH 175	80	95	44	131
EFGCH 185	80	105	44	141
EFGCH 195	80	115	44	151

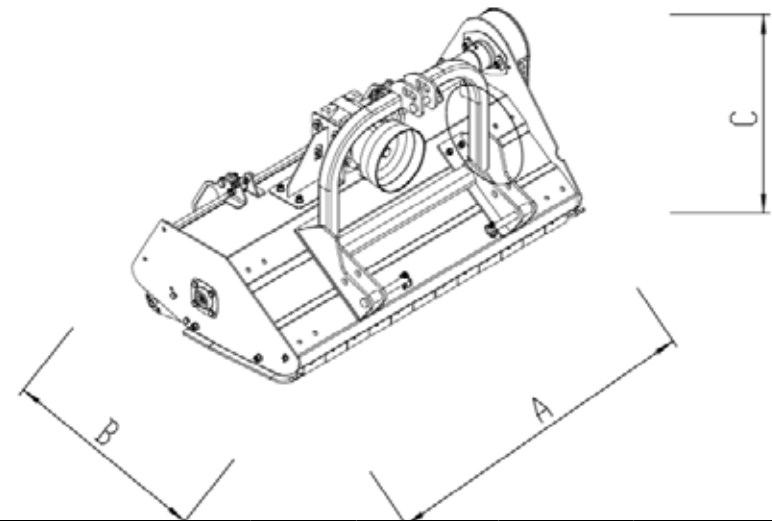

Mod.	Cod.	Larghezza di lavoro (cm)	A (cm)	B (cm)	C (cm)	HP/Kw	Kg	Cinghie	Coltelli	Martelli
EFGCH 125	3.31.125	125	138	95	94	25-40 / 18-29	240	2	40	20
EFGCH 145	3.32.145	145	160	95	94	25-40 / 18-29	270	3	48	24
EFGCH 155	3.33.155	155	170	95	94	30-40 / 22-30	285	3	48	24
EFGCH 165	3.34.165	165	180	95	94	40-60 / 30-44	300	3	56	28
EFGCH 175	3.35.175	175	192	95	94	40-60 / 30-44	315	4	56	28
EFGCH 185	3.36.185	185	202	95	94	40-60 / 30-44	335	4	64	32
EFGCH 195	3.36.195	195	212	95	94	40-60 / 30-44	340	4	64	32

EFGCH OT

TRINCIATRICE CON SPOSTAMENTO IDRAULICO



 **25-60 HP**



- Scatola ingranaggi in ghisa con ruota libera integrata
- Lubrificazione scatola ingranaggi: olio SAE 90
- Potenza di trasmissione applicabile: 50 HP
- Rullo posteriore registrabile in altezza con raschia fango
- Tenditore cinghie regolabile
- Controcoltello dentato
- Spessore fiancate laterali: 6 mm
- Slitte laterali registrabili
- Rotore con sistema di taglio lineare
- Spostamento laterale idraulico: 360 mm
- Cofano apribile per facilitare le operazioni di manutenzione





 Ø: 3-4 cm

UTENSILI					
					
A		R		A	
A (mm)	R (mm)		A (mm)	R (mm)	
50	110	300 gr	90	95	600 gr

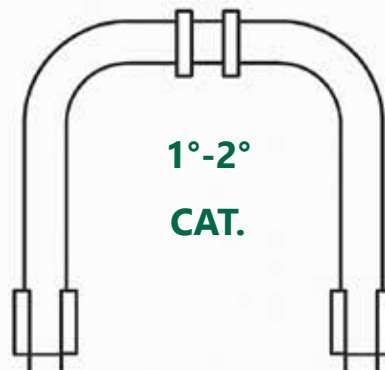
ATTACCO TERZO PUNTO

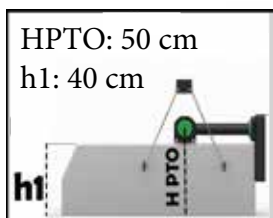
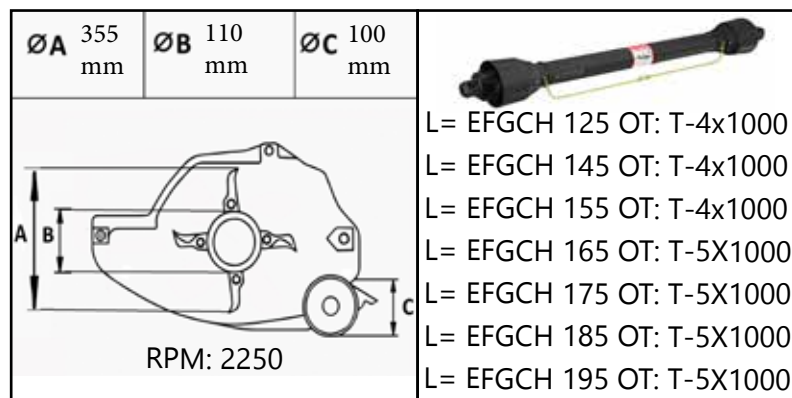



Area di lavoro (cm)				
EFGCH 125 OT	80	45	44	81
EFGCH 145 OT	80	65	44	101
EFGCH 155 OT	80	75	44	111
EFGCH 165 OT	80	85	44	121
EFGCH 175 OT	80	95	44	131
EFGCH 185 OT	80	105	44	141
EFGCH 195 OT	80	115	44	151

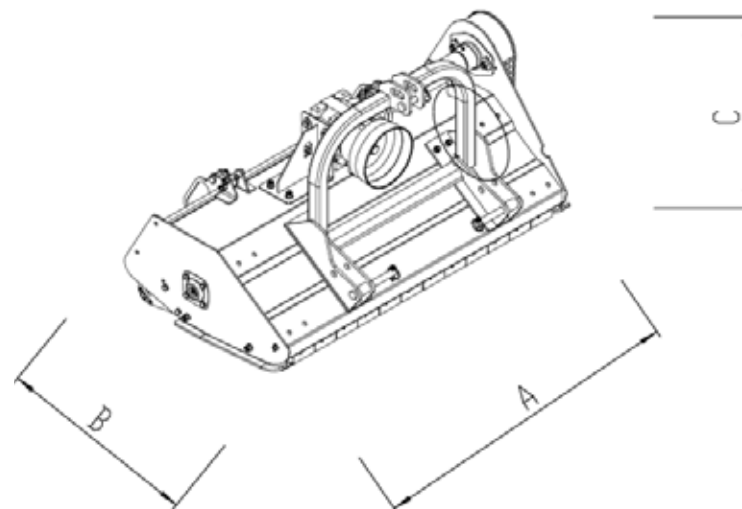

Mod.	Cod.	Larghezza di lavoro (cm)	A (cm)	B (cm)	C (cm)	HP/Kw	Kg	Cinghie	Coltelli	Martelli
EFGCH 125 OT	3.44.125	125	138	95	94	25-40 / 18-29	240	2	40	20
EFGCH 145 OT	3.44.145	145	160	95	94	25-40 / 18-29	270	3	48	24
EFGCH 155 OT	3.44.155	155	170	95	94	30-40 / 22-30	285	3	48	24
EFGCH 165 OT	3.44.165	165	180	95	94	40-60 / 30-44	300	3	56	28
EFGCH 175 OT	3.44.175	175	192	95	94	40-60 / 30-44	315	4	56	28
EFGCH 185 OT	3.44.185	185	202	95	94	40-60 / 30-44	335	4	64	32
EFGCH 195 OT	3.44.195	195	212	95	94	40-60 / 30-44	340	4	64	32

DP

TRINCIATRICE CON SCARICO POSTERIORE AL RULLO

 40-70 HP



 Ø: 3-5 cm



- Scatola ingranaggi in ghisa con ruota libera integrata
- Lubrificazione scatola ingranaggi: olio SAE 90
- Potenza di trasmissione applicabile: 50 HP
- Rullo posteriore registrabile in altezza con raschia fango
- Tenditore cinghie regolabile
- Controcoltello dentato
- Spessore fiancate laterali: 8 mm
- Slitte laterali registrabili
- Rotore con sistema di taglio lineare
- Spostamento laterale idraulico: 420 mm
- Scarico posteriore al rullo
- Barre cromate Ø 48 mm
- Piedino di appoggio
- Protezione anteriore a catene

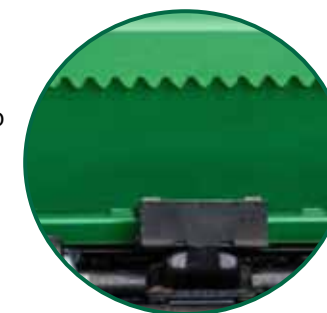

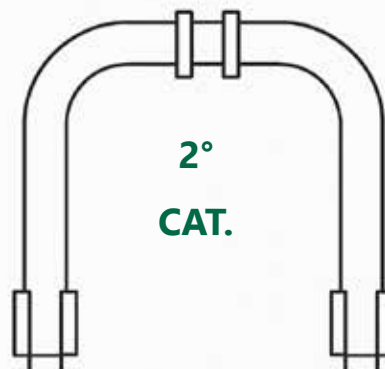

ATTACCO TERZO PUNTO



Scarico posteriore al rullo

UTENSILI

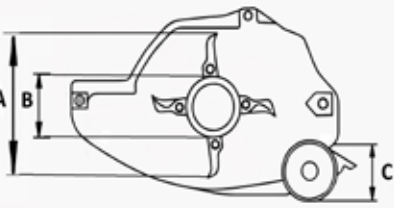
 		 			
A (mm)	R (mm)	(gr)	A (mm)	R (mm)	(gr)
50	110	300	90	95	600

$\varnothing A$ 355 mm	$\varnothing B$ 125 mm	$\varnothing C$ 150 mm	 <p>RPM: 2250</p>
 <p>L= DP 155: T-5x1000 L= DP 165: T-5x1000 L= DP 175: T-5x1000 L= DP 185: T-6x1000 L= DP 195: T-6x1000 L= DP 205: T-6x1000</p>			



HPTO: 45 cm
h1: 42 cm

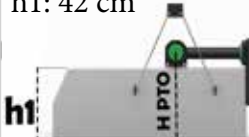

Area di lavoro (cm)				
DP 155	90	65	48	107
DP 165	90	75	48	117
DP 175	90	85	48	127
DP 185	90	95	48	137
DP 195	104	91	62	133
DP 205	104	101	62	143
DP 220	120	100	78	142

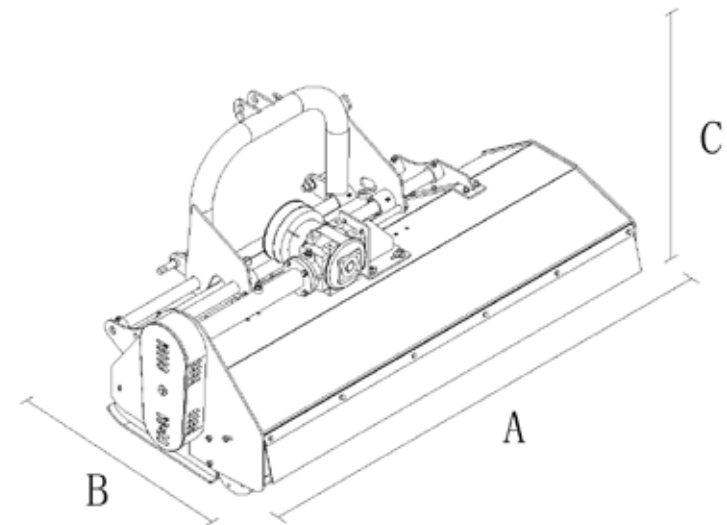

Mod.	Cod.	Larghezza di lavoro (cm)	A (cm)	B (cm)	C (cm)	HP/kW	Kg	Cinghie	Coltelli	Martelli
DP 155	3.35.155	155	170	93	88	40-65 / 30-48	350	4	48	24
DP 165	3.35.165	165	180	93	88	40-65 / 30-48	365	4	56	28
DP 175	3.36.175	175	190	93	88	40-65 / 30-48	380	4	56	28
DP 185	3.38.185	185	200	93	88	40-65 / 30-48	390	4	64	32
DP 195	3.38.195	195	210	93	88	60-70 / 45-52	400	4	64	32
DP 205	3.37.205	205	220	93	88	60-70 / 45-52	405	4	64	32

DP 220

TRINCIATRICE CON SCARICO POSTERIORE AL RULLO

 40-70 HP



 Ø: 3-5 cm



- Scatola ingranaggi in ghisa con ruota libera integrata
- Lubrificazione scatola ingranaggi: olio SAE 90
- Potenza di trasmissione applicabile: 50 HP
- Rullo posteriore registrabile in altezza con raschia fango
- Tenditore cinghie regolabile
- Controcoltello dentato
- Spessore fiancate laterali: 8 mm
- Slitte laterali regolabili
- Rotore con sistema di taglio lineare
- Spostamento laterale idraulico: 420 mm
- Scarico posteriore al rullo
- Scozza rinforzata maggiorata
- Barre cromate Ø 61 mm
- Piedino di appoggio
- Protezione anteriore a catene

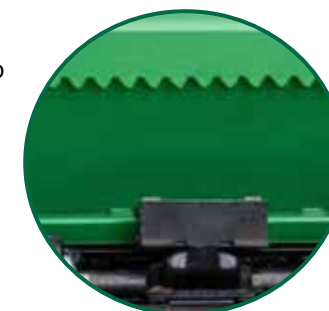

ATTACCO TERZO PUNTO

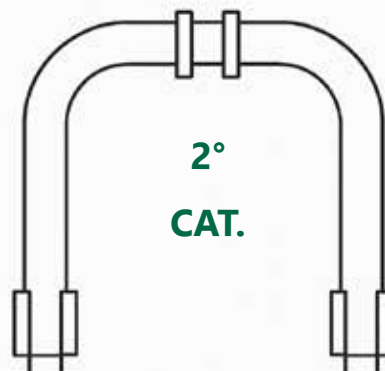

Scarico posteriore al rullo

UTENSILI

 		 			
A (mm)	R (mm)	(gr)	A (mm)	R (mm)	(gr)
50	110	300	90	95	600

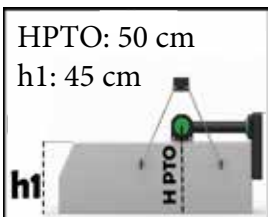
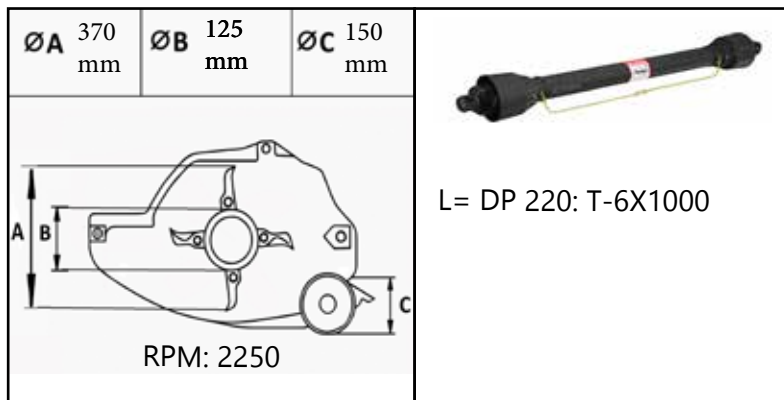

Area di lavoro (cm)	[Blue] [Orange]		[Blue] [Orange]	
DP 220	120	100	78	142

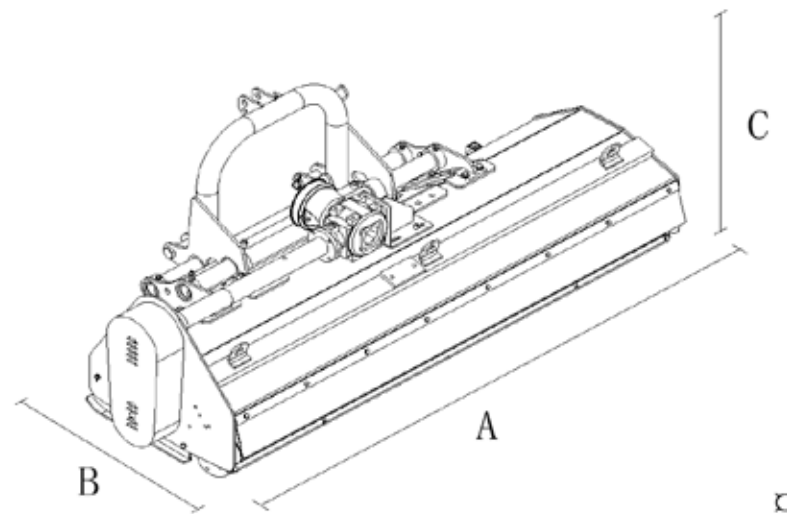

Mod.	Cod.	Larghezza di lavoro (cm)	A (cm)	B (cm)	C (cm)	HP/kW	Kg	Cinghie	Coltelli	Martelli
DP 220	3.38.220	220	240	91	94	60-70 / 45-52	505	4	68	34

MA

TRINCIATRICE PER VIGNETO FRUTTETO CON SPOSTAMENTO IDRAULICO



 **35-85 HP**



- Scatola ingranaggi in ghisa con ruota libera integrata
- Lubrificazione scatola ingranaggi: olio SAE 90
- Potenza di trasmissione applicabile: 50 HP
- Rullo posteriore registrabile in altezza con raschia fango
- Tenditore cinghie regolabile
- Controcoltello dentato
- Spessore fiancate laterali: 8 mm
- Slitte laterali registrabili
- Rotore con sistema di taglio lineare
- Spostamento laterale idraulico: 450 mm
- Barre cromate Ø 50 mm
- Piedino di appoggio
- Protezione anteriore a catene
- Cofano apribile per facilitare le operazioni di manutenzione
- Scocca con doppia lamiera di rinforzo

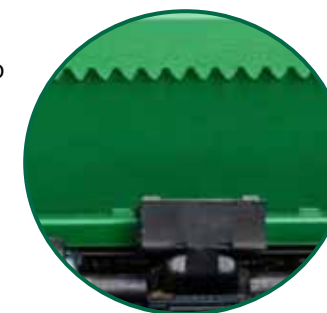

 **Ø: 4-5 cm**

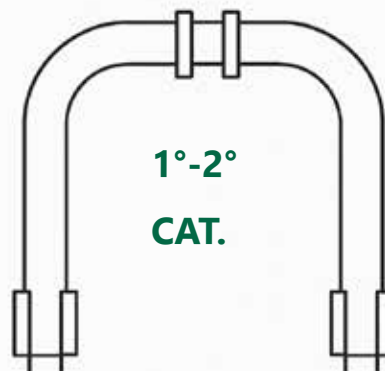

ATTACCO TERZO PUNTO

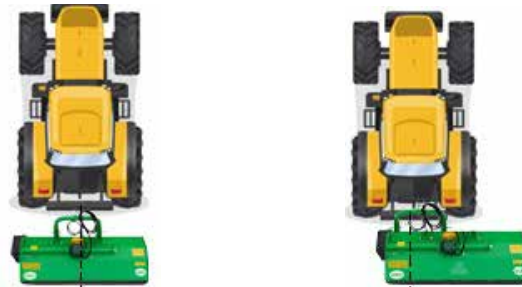
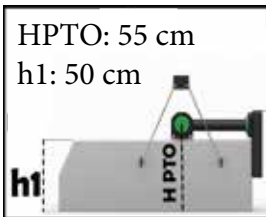
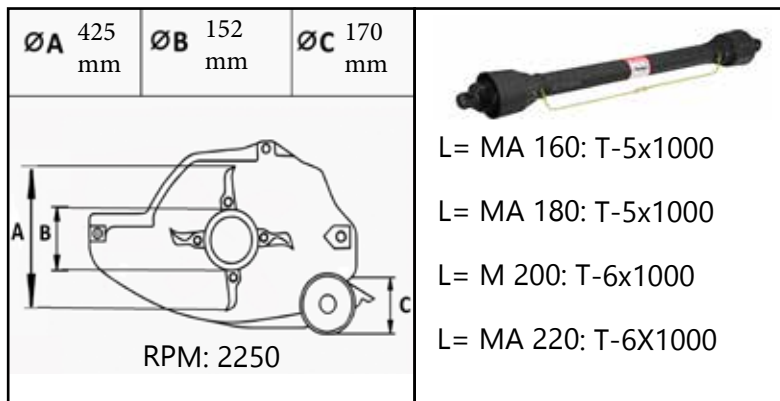

UTENSILI

 		 			
A (mm)	R (mm)	(gr)	A (mm)	R (mm)	(gr)
50	110	300	90	100	800



Area di lavoro (cm)				
MA 160	106	54	60	100
MA 180	106	74	60	120
MA 200	106	94	60	140
MA 220	106	114	60	160

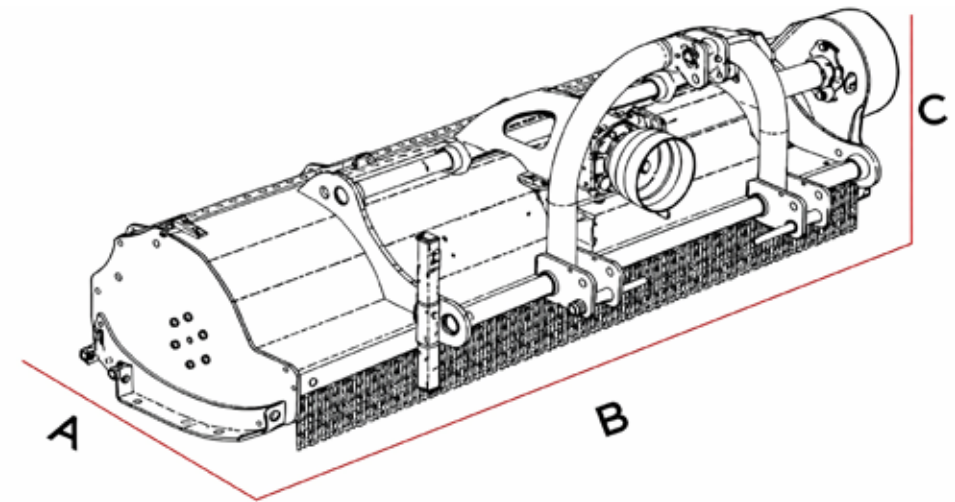

Mod.	Cod.	Larghezza di lavoro (cm)	A (cm)	B (cm)	C (cm)	HP	Kg	Cinghie	Coltelli	Martelli
MA 160	3.52.160	160	102	180	155	35-85	485	4	44	22
MA 180	3.52.180	180	102	200	175	35-85	505	4	48	24
MA 200	3.52.200	200	102	220	195	35-85	524	4	52	26
MA 220	3.52.220	220	102	240	215	35-85	545	4	56	28

MA DISK

DISCO PER TRINCIATRICE



 **35-85 HP**



- Motore idraulico GR2 14cc
- Molla antiurto con regolazione manuale
- Molla di regolazione dell'inclinazione
- Disco da 650 mm
- Flusso idraulico minimo 25 Lt/min
- Doppia lama pivotante
- Regolazione in altezza con sistema flottante (20 cm)



UTENSILI



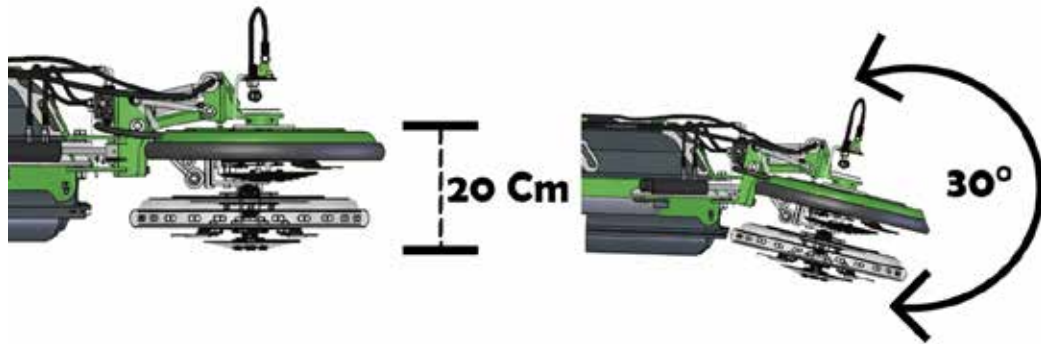

Caratteristica	Unità metrica
Larghezza di taglio	650.0 mm
Peso	46 kg
Velocità rotazione lame	2300 rpm @t 30 Lt
Flusso ottimale dell'olio	30 l/min Max

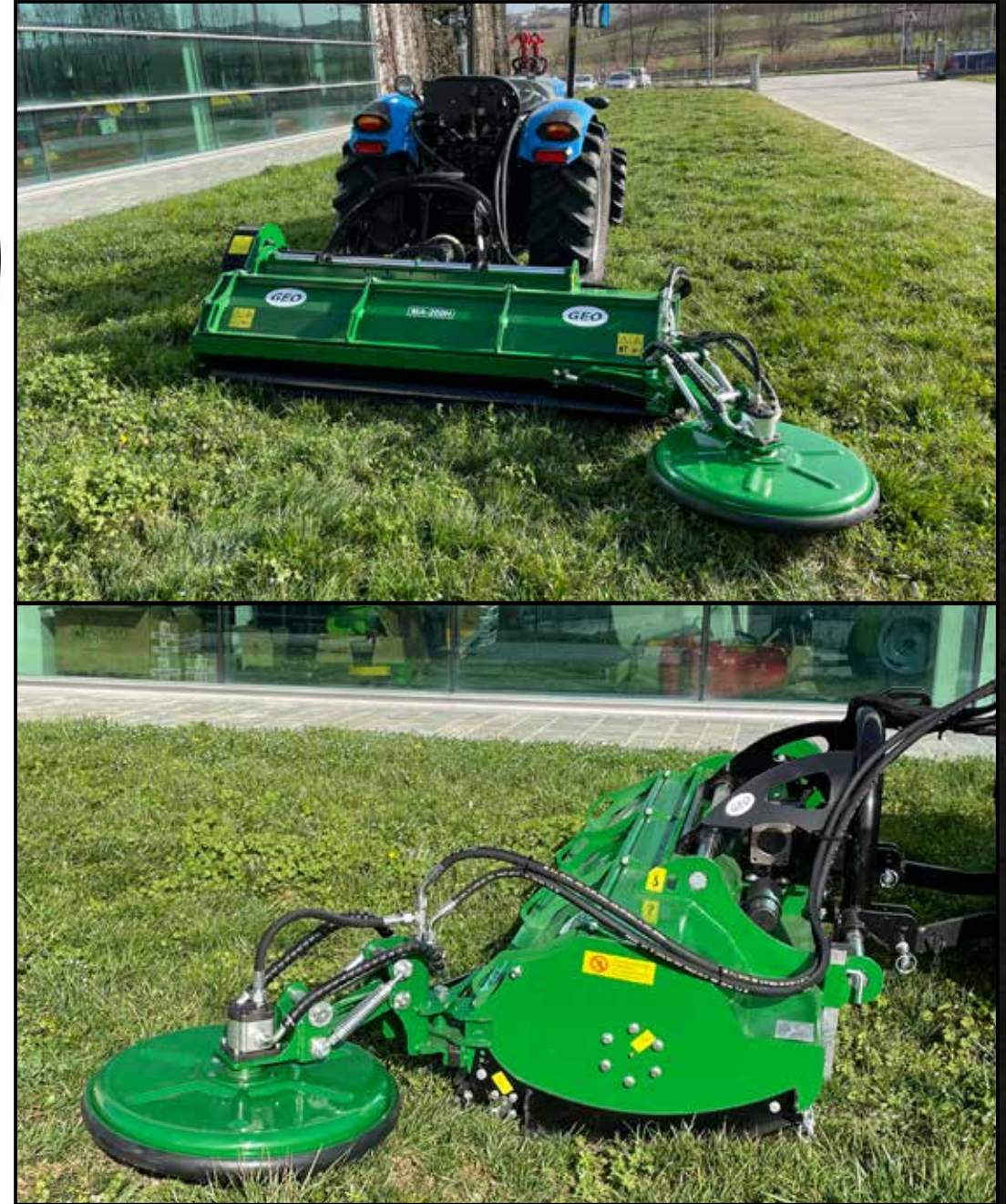
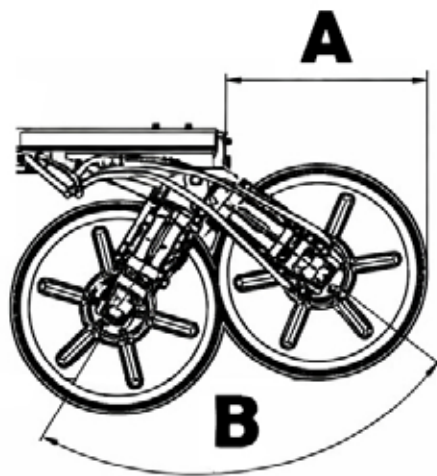

Mod.	Cod.	Ø (mm)	A (mm)	B (°)	Lame
DISK MA	3.52	650	664	83°	2

GKK

TRINCIATRICE PESANTE CON SPOSTAMENTO IDRAULICO



 **60-80 HP**



- Scatola ingranaggi in ghisa con ruota libera integrata
- Lubrificazione scatola ingranaggi: olio SAE 90
- Potenza di trasmissione applicabile: 50 HP
- Rullo posteriore registrabile in altezza con raschia fango
- Tenditore cinghie regolabile
- Controcoltello dentato
- Spessore fiancate laterali: 6 mm
- Slitte laterali registrabili
- Rotore con sistema di taglio lineare
- Spostamento laterale idraulico: 400 mm
- Piedino di appoggio
- Protezione anteriore combinata a catene e gomma
- Cofano apribile per facilitare le operazioni di manutenzione

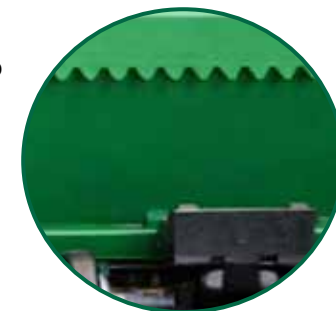

 Ø: 4-5 cm

ATTACCO TERZO PUNTO

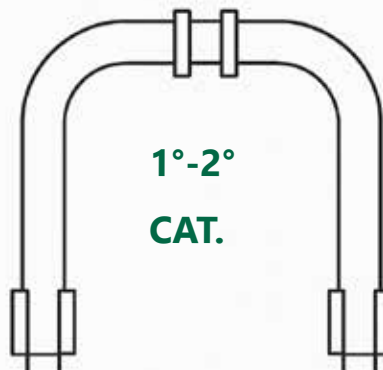

UTENSILI

 		 	
A (mm)	R (mm)	A (mm)	R (mm)
50	110	90	95
 300 gr		 600 gr	

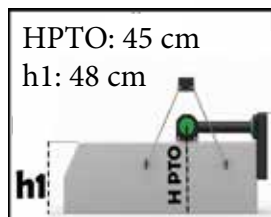
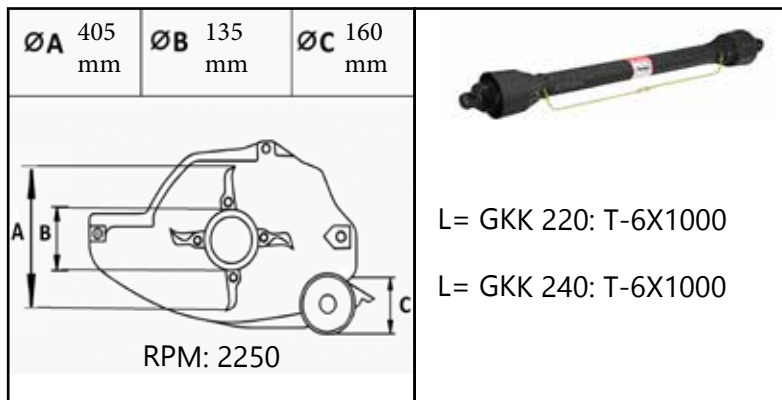

Area di lavoro (cm)				
GKK 220	115	105	75	145
GKK 240	115	125	75	165

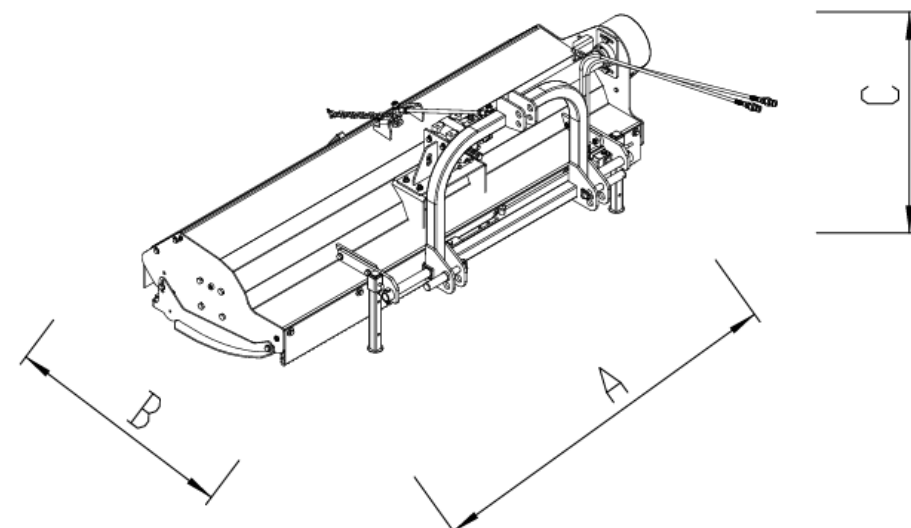

Mod.	Cod.	Larghezza di lavoro (cm)	A (cm)	B (cm)	C (cm)	HP/Kw	Kg	Cinghie	Coltelli	Martelli
GKK 220	3.51.220	220	240	115	102	60-80/44-59	580	4	72	36
GKK 240	3.51.240	240	260	115	102	60-80/44-59	615	4	80	40

FL

TRINCIATRICE CON RACCOGLITORE





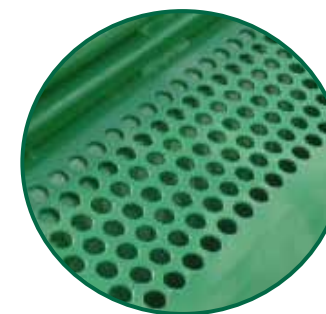

 **25-50 HP**



- Scatola ingranaggi in ghisa con ruota libera integrata
- Lubrificazione scatola ingranaggi: olio SAE 90
- Potenza di trasmissione applicabile: 50 HP
- Tenditore cinghie regolabile
- Spessore fiancate laterali: 5 mm
- Rotore con sistema di taglio lineare
- Apertura cassone con pistone singolo FL 120
- Apertura cassone con pistone doppio FL 180
- Ruote pivottanti regolabili in altezza
- Capacità serbatoio: 720-960 Lt
- Prese d'aria per aerazione



 **Ø: 2-3 cm**

UTENSILI		
 		
		
A (mm)	R (mm)	(gr)
80	80	400

ATTACCO TERZO PUNTO

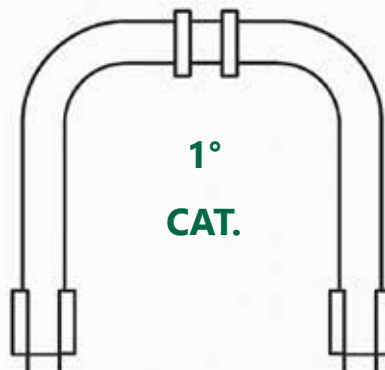

ØA 325 mm ØB 110 mm ØC 100 mm

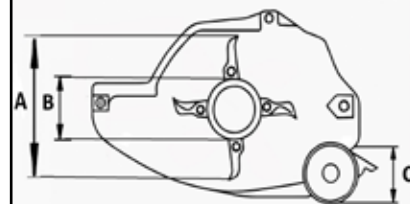

RPM: 2250





L= FL 120: T-4X800

L= FL 160: T-5X800



HPTO: 40 cm



Area di lavoro (cm)		
FL 120	60	60
FL 160	80	80

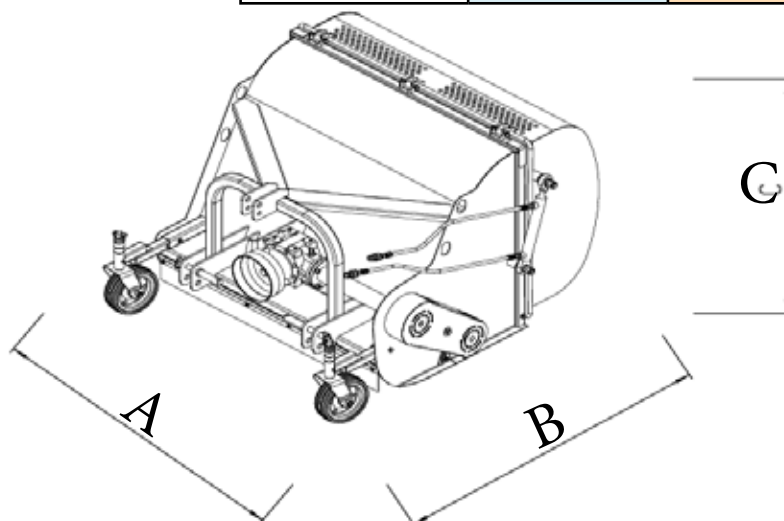

● ● ● TRINCIATRICE CON RACCOGLITORE

Mod.	Cod.	Larghezza di lavoro (cm)	A (cm)	B (cm)	C (cm)	HP/Kw	Kg	Cinghie	Capacità (L)	Martelli
FL 120	5.12.120	120	134	150	102	25-50 / 18-37	325	2	720	20
FL 160	5.13.160	160	186	150	102	25-60 / 18-44	367	3	960	28

FLP 180

TRINCIATRICE PESANTE CON RACCOGLITORE



50-100 HP

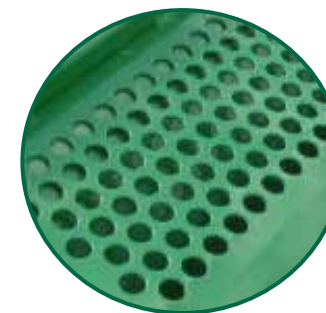

- Scatola ingranaggi in ghisa con ruota libera integrata
- Lubrificazione scatola ingranaggi: olio SAE 90
- Potenza di trasmissione applicabile: 50 HP
- Tenditore cinghie regolabile
- Spessore fiancate laterali: 6 mm
- Rotore con sistema di taglio lineare
- Scarico a terra con doppia apertura idraulica
- Sistema di apertura idraulica con valvole di blocco
- Ruote pivotanti regolabili in altezza
- Forcelle ruote con molle di posizionamento
- Capacità serbatoio: 2000 Lt
- Prese d'aria per aerazione

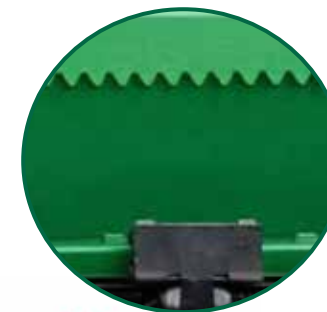

Ø: 3-4 cm

UTENSILI		
		M16
A	R	
A (mm)	R (mm)	(gr)
90	95	600

ATTACCO TERZO PUNTO

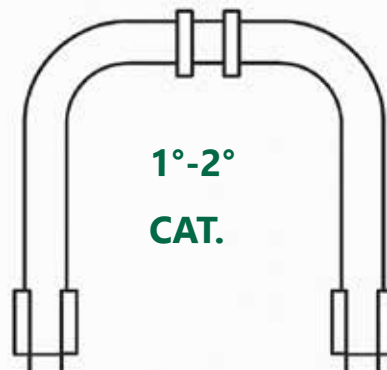

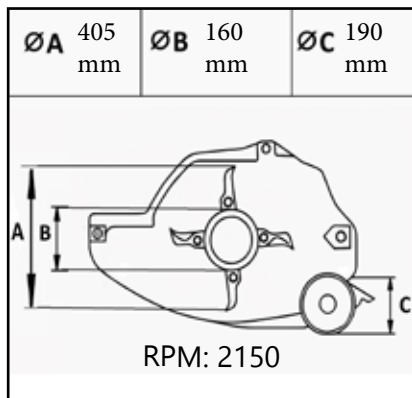

L= FLP 180: T-5X800

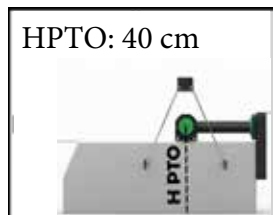

Area di lavoro (cm)		
FLP 180	90	90

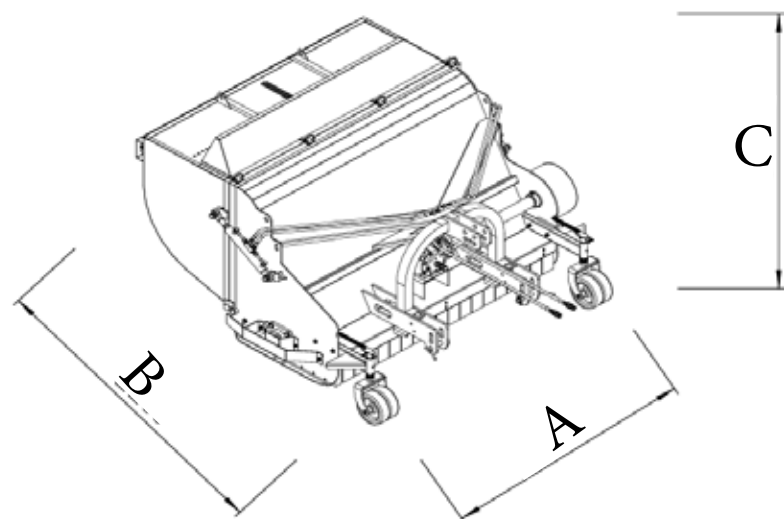

Mod.	Cod.	Larghezza di lavoro (cm)	A (cm)	B (cm)	C (cm)	HP/kW	Kg	Cinghie	Capacità (L)	Martelli
FLP 180	5.13.180	180	220	220	140	50-100/37-74	850	4	2000	24

DPG

TRINCIATRICE REVERSIBILE CON SPOSTAMENTO IDRAULICO PER TRATTORI REVERSIBILI

 50-75 HP



 Ø: 3-5 cm

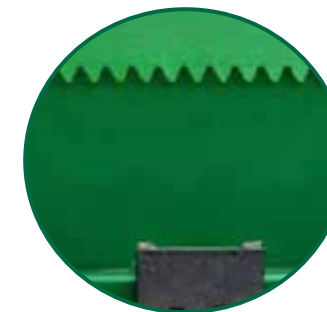

- Scatola ingranaggi in ghisa con doppia ruota libera integrata
- Lubrificazione scatola ingranaggi: olio SAE 90
- Potenza di trasmissione applicabile: 50 HP
- Rullo posteriore registrabile in altezza con raschia fango
- Tenditore cinghie regolabile
- Controcotello dentato
- Spessore fiancate laterali: 8 mm
- Slitte laterali registrabili
- Rotore con sistema di taglio lineare
- Spostamento laterale idraulico: 420 mm
- Scarico posteriore al rullo
- Barre cromate Ø 61 mm
- Piedino di appoggio
- Protezione anteriore a catene

UTENSILI

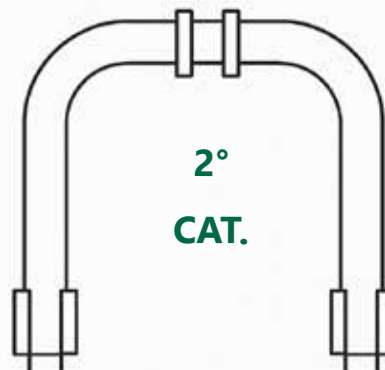

 		 	
A (mm)	R (mm)	A (mm)	R (mm)
50	110	90	95
 300		 600	

ATTACCO TERZO PUNTO

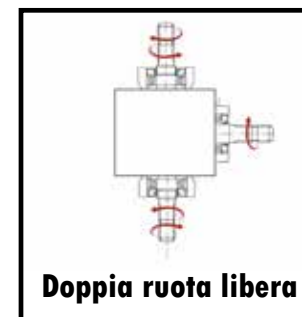

Scarico posteriore al rullo

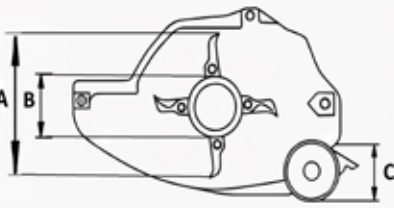

$\varnothing A$ 355 mm	$\varnothing B$ 110 mm	$\varnothing C$ 150 mm	
			



L = DPG 145: T-5x1000
L = DPG 155: T-5x1000
L = DPG 165: T-5x1000
L = DPG 175: T-5x1000
L = DPG 185: T-6x1000
L = DPG 195: T-6x1000
L = DPG 205: T-6x1000

RPM: 2250

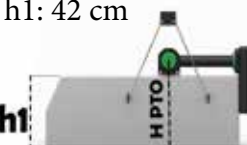

HPTO: 45 cm
h1: 42 cm

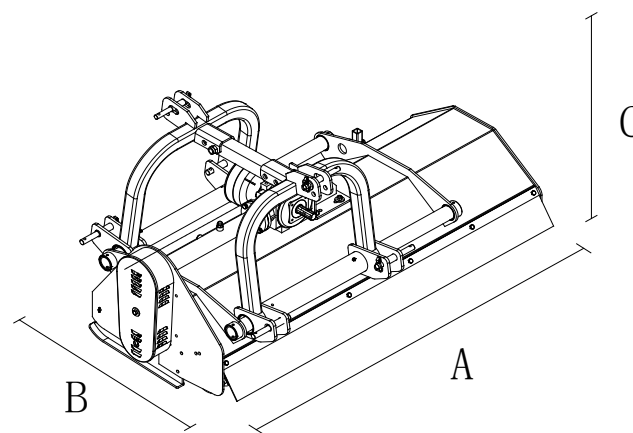
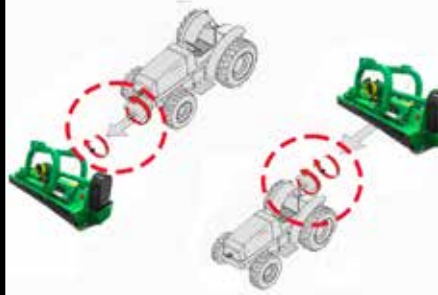

Area di lavoro (cm)				
DPG 145	92	53	50	95
DPG 155	92	63	50	105
DPG 165	92	73	50	115
DPG 175	92	83	50	125
DPG 185	92	93	50	135
DPG 195	106	89	64	131
DPG 205	106	99	64	141

SCATOLA INGRANAGGI CON
DOPPIA RUOTA LIBERA

Mod.	Cod.	Larghezza lavoro (cm)	A (cm)	B (cm)	C (cm)	HP/Kw	Kg	Cinghie	Martelli
DPG 145	3.80.145	145	159	102	92	50 / 37	322	4	24
DPG 155	3.80.155	155	169	102	92	50 / 37	342	4	24
DPG 165	3.80.165	165	179	102	92	75 / 50	362	4	28
DPG 175	3.80.175	175	189	102	92	75 / 50	382	4	28
DPG 185	3.80.185	185	199	102	92	75 / 50	402	4	32
DPG 195	3.80.195	195	209	102	92	75 / 50	422	4	32
DPG 205	3.80.205	205	219	102	92	75 / 50	452	4	32

AGN

TRINCIATRICE REVERSIBILE CON SPOSTAMENTO IDRAULICO PER TRATTORI FRONTALI

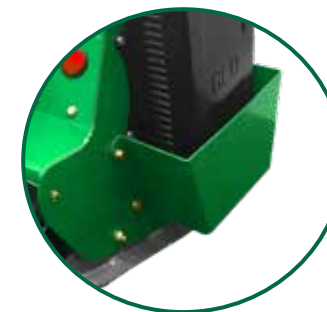
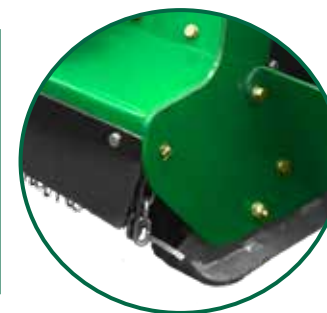

 **40-85 HP**



- Scatola ingranaggi in ghisa con ruota libera integrata
- Lubrificazione scatola ingranaggi: olio SAE 90
- Potenza di trasmissione applicabile: 50 HP
- Rullo posteriore registrabile in altezza con raschia fango
- Tenditore cinghie regolabile
- Controcotello dentato, fissato con bulloni (sostituibile)
- Spessore fiancate laterali: 9 mm
- Slitte laterali registrabili
- Rotore con sistema di taglio lineare
- Spostamento laterale idraulico: 450 mm
- Protezione anteriore combinata a catene e gomma
- Barre cromate Ø 61 mm
- Attacco frontale e posteriore
- PTO 540 o 1000rpm con inversione pulegge

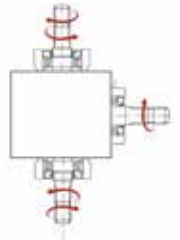

Ø: 4-5 cm

UTENSILI		OPZIONAL
		
A (mm)	R (mm)	 1200 (gr) Doppia ruota libera
140	100	

ATTACCO TERZO PUNTO

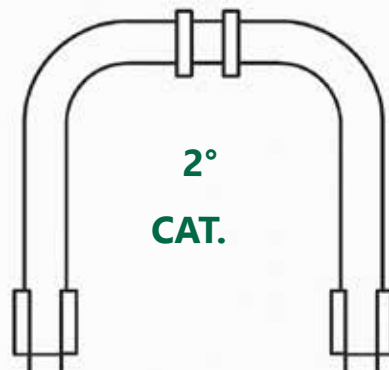

PTO 540 / 1000 giri/min
Inversione delle pulegge.

540 rpm

1000 rpm

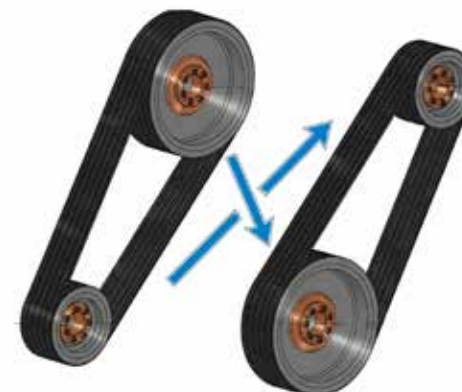

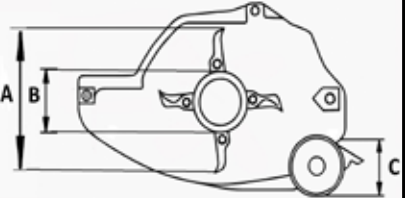

$\varnothing A$ 380 mm	$\varnothing B$ 125 mm	$\varnothing C$ 150 mm	 L=AGN 140: T-5x1000 L= AGN 160: T-5x1000 L= AGN 180: T-6x1000 L= AGN 200: T-6x1000 L= AGN 220: T-6X1000 L= AGN 240: T-6x1000
 RPM: 2150			

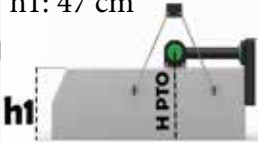

HPTO: 57 cm
h1: 47 cm



Area di lavoro (cm)				
AGN 140	90	50	50	90
AGN 160	90	70	50	110
AGN 180	119	61	69	111
AGN 200	125	75	75	125
AGN 220	125	95	75	145
AGN 240	125	115	75	165

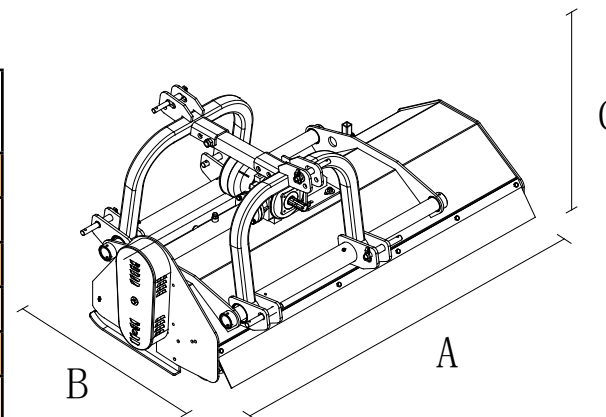

Mod.	Cod.	Larghezza lavoro (cm)	A (cm)	B (cm)	C (cm)	HP/Kw	Kg	Cinghie	Martelli
AGN 140	3.36.140	140	156	100	99	40/30	440	3	12
AGN 160	3.36.160	160	176	100	99	50/37	500	3	14
AGN 180	3.36.180	180	196	100	99	75/50	530	3	16
AGN 200	3.36.200	200	216	100	99	85/63	560	4	18
AGN 220	3.36.220	220	236	100	99	85/63	580	4	20
AGN 240	3.36.240	240	256	100	99	85/63	605	4	22

AGS

TRINCIATRICE LEGGERA LATERALE/SBANCHINATRICE

GEO
Macchine Agricole



15-35HP

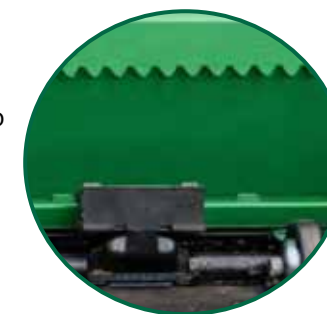

- Scatola ingranaggi in ghisa con ruota libera integrata
- Lubrificazione scatola ingranaggi: olio SAE 90
- Potenza di trasmissione applicabile: 35 HP
- Rullo posteriore registrabile in altezza con raschia fango
- Tenditore cinghie regolabile
- Controcoltello dentato
- Spessore fiancate laterali: 6 mm
- Slitte laterali regolabili
- Rotore con sistema di taglio lineare
- Doppio pistone per movimentazione trincia
- Spostamento laterale idraulico
- Piedino di appoggio



Ø: 1-2cm

UTENSILI

A	R	A	R
A (mm)	R (mm)	A (mm)	R (mm)
50	80	80	80
(gr)		(gr)	
150		400	

ATTACCO TERZO PUNTO

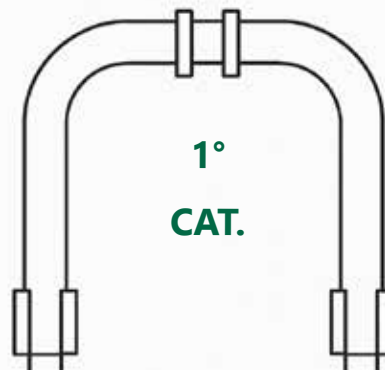

ØA 292 mm	ØB 77 mm	ØC 100 mm
-----------	----------	-----------

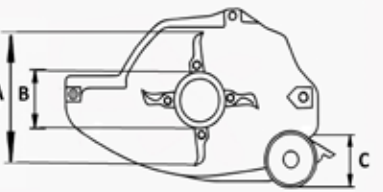

RPM: 1850



L= AGS 105: T-4X1700



HPTO: 43 cm
h1: 30 cm

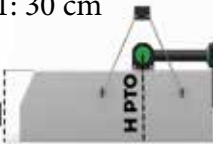

Mod	M (cm)	N (cm)	O (cm)	P (cm)
AGS 105	65	40	137	32

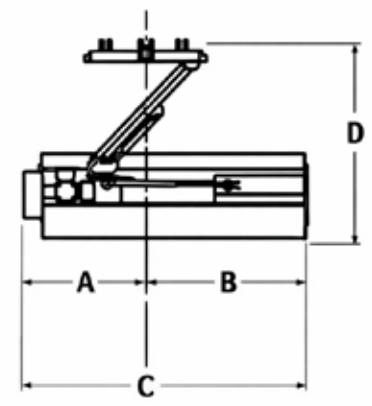
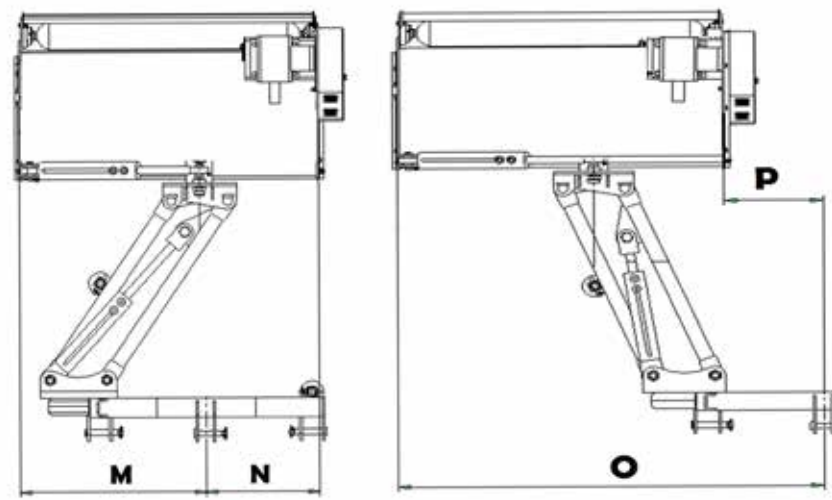

Mod.	Cod.	Larghezza lavoro (cm)	A (cm)	B (cm)	C (cm)	D (cm)	HP/Kw	Kg	Cinghie	Coltelli
AGS 105	3.62.105	105	48	65	113	211	15-35 / 15-26	215	2	36

AGL

TRINCIATRICE LEGGERA LATERALE/SBANCHINATRICE



 30-50 HP



- Scatola ingranaggi in ghisa con ruota libera integrata
- Lubrificazione scatola ingranaggi: olio SAE 90
- Potenza di trasmissione applicabile: 50 HP
- Rullo posteriore registrabile in altezza
- Tenditore cinghie regolabile
- Controcoltello dentato
- Spessore fiancate laterali: 6 mm
- Slitte laterali
- Rotore con sistema di taglio lineare
- Doppio pistone per movimentazione trincia
- Spostamento laterale idraulico
- Piedino di appoggio
- Catene frontali

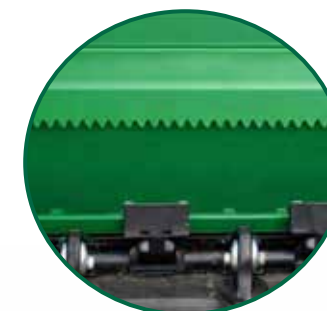





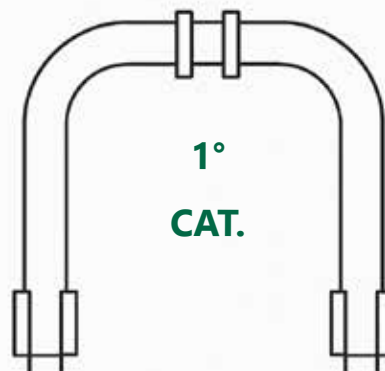

 Ø: 2-3 cm

ATTACCO TERZO PUNTO



UTENSILI

  		  			
A (mm)	R (mm)	(gr)	A (mm)	R (mm)	(gr)
50	80	150	80	80	400

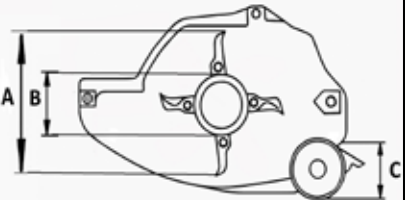
ØA 325 mm	ØB 110 mm	ØC 100 mm	 <p>L= AGL 125: T-4X1700 L= AGL 145: T-4X1700 L= AGL 165: T-5X1700</p>
 <p>RPM: 2250</p>			



HPTO: 45 cm
h1: 35 cm

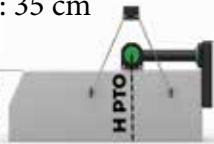

Mod.	M (cm)	N (cm)	O (cm)	P (cm)
AGL 125	64	62	167	41
AGL 145	84	62	187	41
AGL 165	104	62	207	41

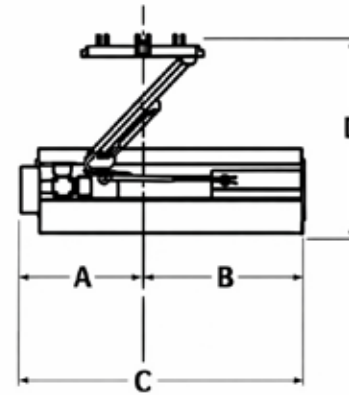
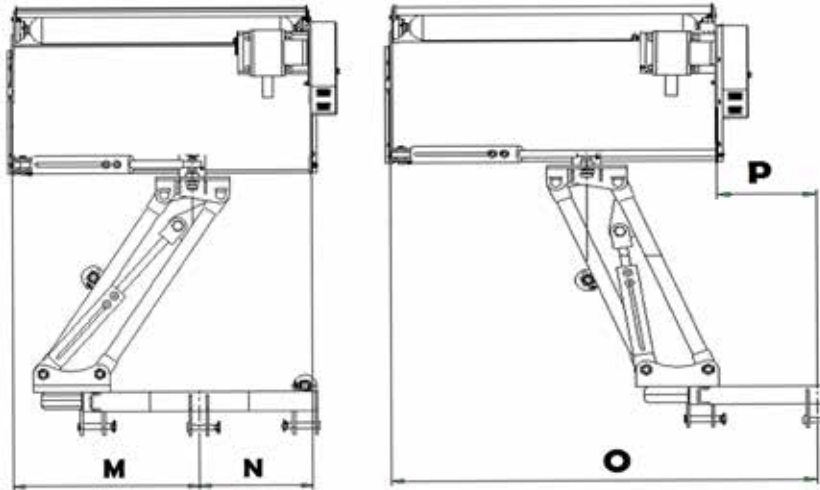

Mod.	Cod.	Larghezza di lavoro (cm)	A (cm)	B (cm)	C (cm)	D (cm)	HP/Kw	Angolo	Kg	Cinghie	Coltelli	Martelli
AGL 125	3.60.125	125	72	64	136	205	30-50 / 22-37	-55° e + 90°	250	3	42	21
AGL 145	3.60.145	145	72	84	156	205	30-50 / 22-37	-55° e + 90°	280	3	48	24
AGL 165	3.60.165	165	72	104	176	205	30-50 / 22-37	-55° e + 90°	310	3	54	27

AGL-C

TRINCIATRICE LEGGERA LATERALE/SBANCHINATRICE



 30-60 HP



- Scatola ingranaggi in ghisa con ruota libera integrata
- Lubrificazione scatola ingranaggi: olio SAE 90
- Potenza di trasmissione applicabile: 50 HP
- Rullo posteriore registrabile in altezza con raschia fango
- Tenditore cinghie automatico
- Controcoltello dentato
- Spessore fiancate laterali: 6 mm
- Slitte laterali registrabili
- Rotore con sistema di taglio lineare
- Doppio pistone per movimentazione trincia
- Spostamento laterale idraulico con sistema anti shock
- Piedino di appoggio
- Valvola di blocco su pistone di alzata
- Regolatori flusso olio







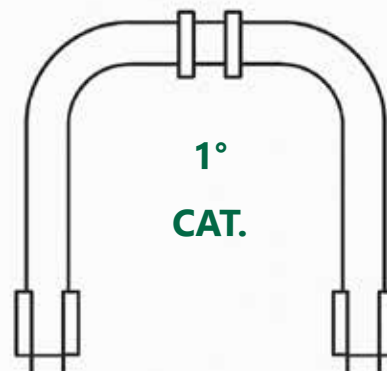



 Ø: 2-3 cm

ATTACCO TERZO PUNTO

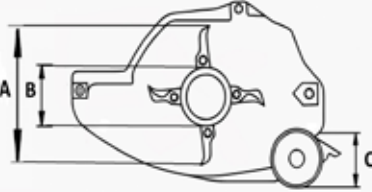

UTENSILI

 		 		
A	R	A	R	
A (mm)	R (mm)	A (mm)	R (mm)	(gr)
50	80	80	80	150
				400

ØA 325 mm	ØB 110 mm	ØC 100 mm		
			L = AGL-C 145: T-4X1700	
RPM: 2250			L = AGL-C 165: T-4X1700	
			L = AGL-C 185: T-5X1700	
ANTISHOCK				



HPTO: 55 cm
h1: 45 cm

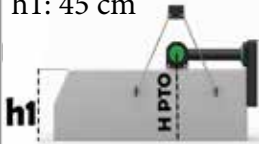

Mod.	M (cm)	N (cm)	O (cm)	P (cm)
AGL 145C	89	65	206	42
AGL 165C	109	65	226	42
AGL 185C	129	65	246	42

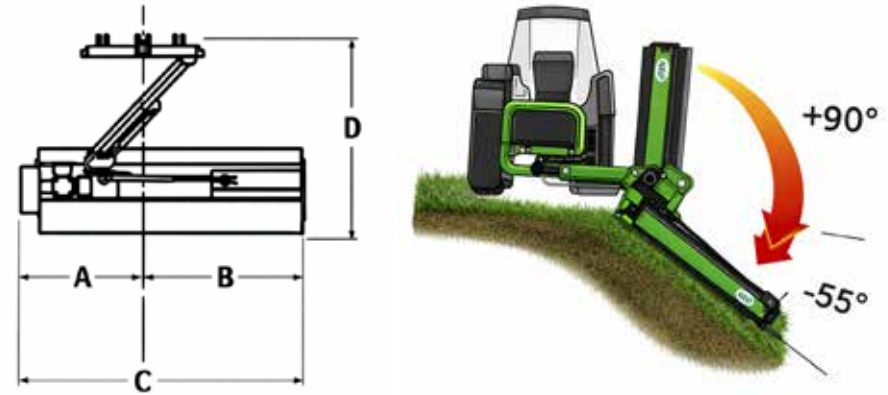
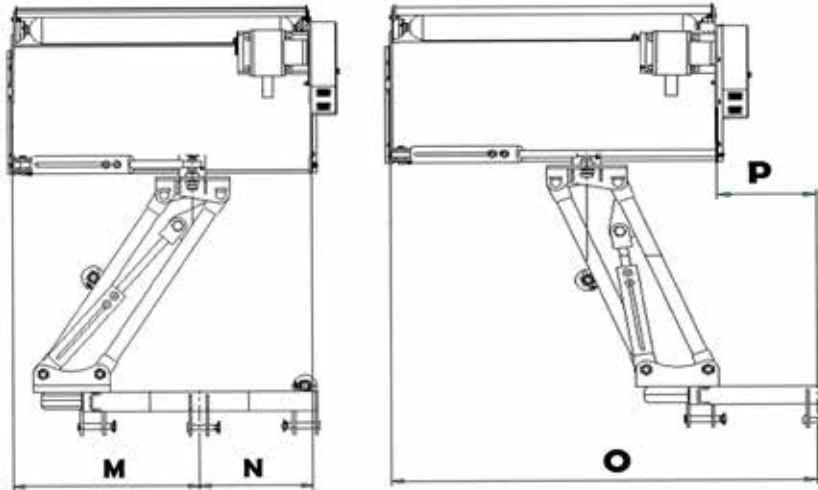

Mod.	Cod.	Larghezza di lavoro (cm)	A (cm)	B (cm)	C (cm)	D (cm)	hP/Kw	Angolo	Kg	Cinghie	Coltelli	Martelli
AGL 145C	3.60.145C	145	99	75	164	205	30-50 / 22-37	-55° e + 90°	330	3	48	24
AGL 165C	3.60.165C	165	119	75	184	205	30-50 / 22-37	-55° e + 90°	342	3	54	27
AGL 185C	3.60.185C	185	139	75	204	205	40/60 - 30/44	-55° e + 90°	365	3	60	30

AGE

TRINCIATRICE LEGGERA LATERALE CON STATOLA ESTERNA

 30-50 HP



- Scatola ingranaggi in ghisa con ruota libera integrata
- Scatola esterna
- Lubrificazione scatola ingranaggi: olio SAE 90
- Potenza di trasmissione applicabile: 50 HP
- Rullo posteriore registrabile in altezza
- Tenditore cinghie regolabile
- Controcottello dentato
- Spessore fiancate laterali: 6 mm
- Slitte laterali
- Rotore con sistema di taglio lineare
- Doppio pistone per movimentazione trincia
- Spostamento laterale idraulico
- Piedino di appoggio







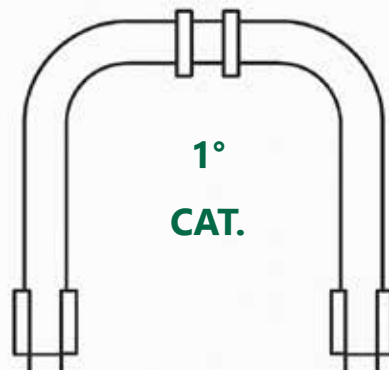

 Ø: 2-3 cm

ATTACCO TERZO PUNTO



UTENSILI

M12		M12	
			
A	R	A	R
A (mm)	R (mm)	A (mm)	R (mm)
50	80	80	80
			
150 gr		400 gr	

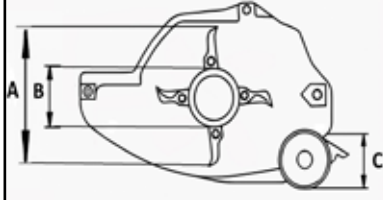
ØA 325 mm	ØB 110 mm	ØC 100 mm	 <p>L= AGE 125: T-4X1700 L= AGE 145: T-4X1700 L= AGE 165: T-4X1700</p>
			
RPM: 2250			



HPTO: 51 cm
h1: 36 cm

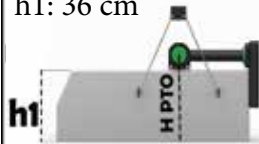

Mod.	M (cm)	N (cm)	O (cm)	P (cm)
AGE 125	64	62	167	41
AGE 145	84	62	187	41
AGE 165	104	62	207	41

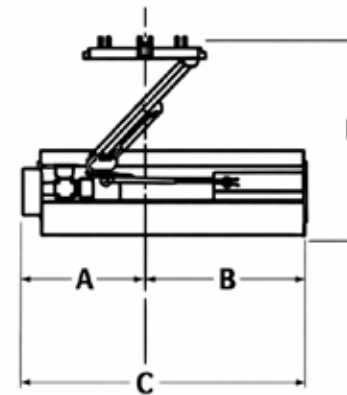
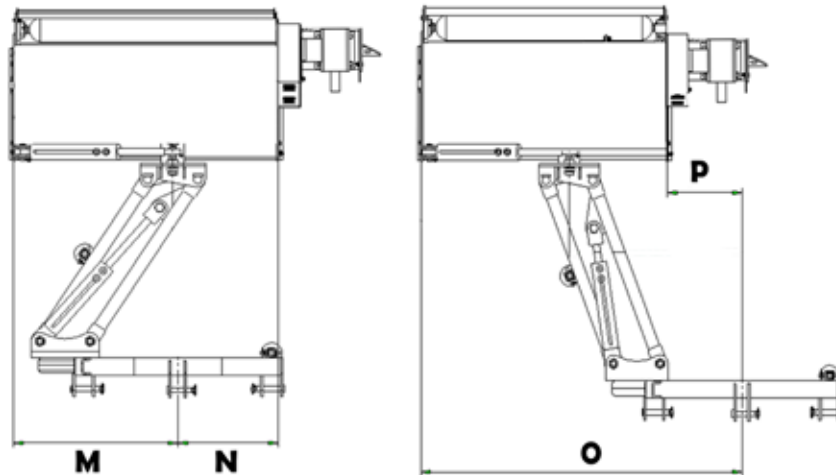

Mod.	Cod.	Larghezza di lavoro (cm)	A (cm)	B (cm)	C (cm)	D (cm)	HP/Kw	Angolo	Kg	Cinghie	Coltelli	Martelli
AGE 125	3.61.125	125	100	64	164	205	30-50 / 22-37	-55° e + 90°	265	3	42	21
AGE 145	3.61.145	145	100	84	185	205	30-50 / 22-37	-55° e + 90°	295	3	48	24
AGE 165	3.61.165	165	100	104	204	205	30-50 / 22-37	-55° e + 90°	325	3	54	27

AGD

TRINCIATRICE LATERALE CON SCARICO POSTERIORE AL RULLO



50-80 HP



- Scatola ingranaggi in ghisa con ruota libera integrata
- Lubrificazione scatola ingranaggi: olio SAE 90
- Potenza di trasmissione applicabile: 50 HP
- Rullo posteriore registrabile in altezza con raschia fango
- Tenditore cinghie registrabile
- Controcoltello dentato
- Spessore fiancate laterali: 8 mm
- Slitte laterali regolabili
- Rotore con sistema di taglio lineare
- Scarico posteriore al rullo
- Doppio pistone per movimentazione trincia
- Spostamento laterale idraulico con sistema anti shock
- Piedino di appoggio
- Valvola di blocco su pistone di alzata
- Regolatori flusso olio
- Protezione anteriore a catene

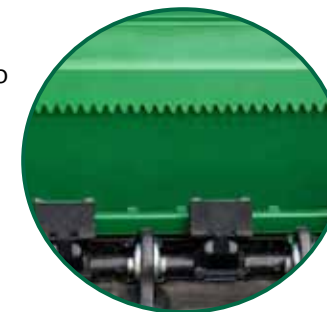

Ø: 3-5 cm



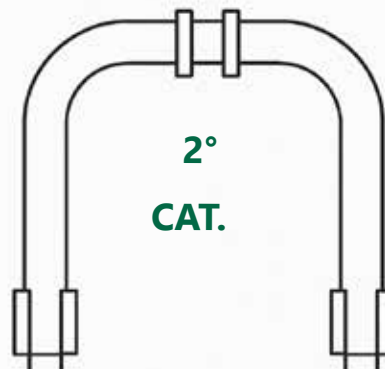

UTENSILI

A (mm)	R (mm)	(gr)	A (mm)	R (mm)	(gr)
50	110	300	90	95	600

ATTACCO TERZO PUNTO

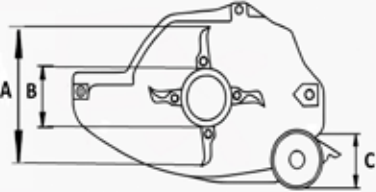

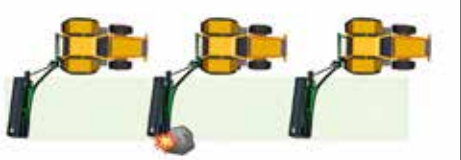
Scarico posteriore al rullo

$\varnothing A$ 355 mm $\varnothing B$ 110 mm $\varnothing C$ 100 mm  RPM: 2250	 L= AGD 155: T-5X1700 L= AGD 175: T-5X1700	 	
		ANTISHOCK	SGANCIO DI SICUREZZA

HPTO: 47 cm
 h1: 35 cm

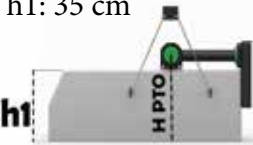

Mod.	M (cm)	N (cm)	O (cm)	P (cm)
AGD 155	95	62	194	38
AGD 175	115	62	215	38

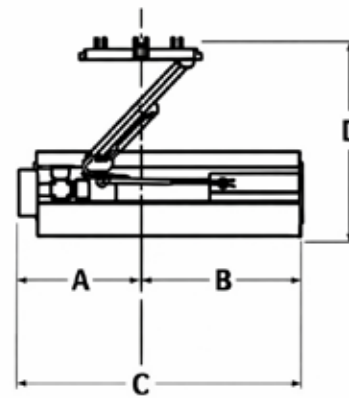
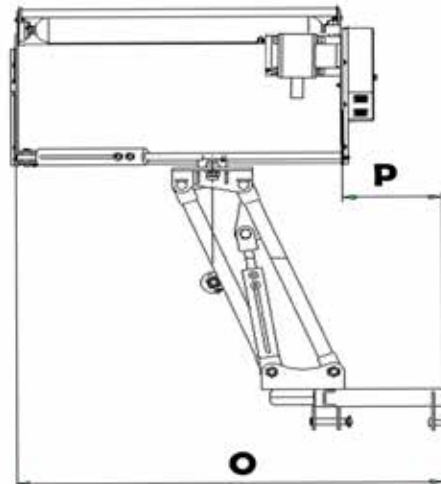
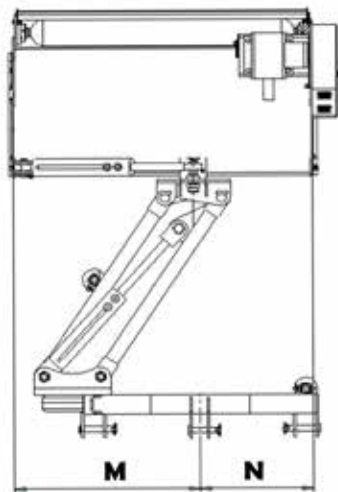

Mod.	Cod.	Larghezza di lavoro (cm)	A (cm)	B (cm)	C (cm)	D (cm)	HP/Kw	Angolo	Kg	Cinghie	Coltelli	Martelli
AGD 155	3.63.155	155	53	115	168	150	50-80 / 37-60	-55° e + 90°	380	4	48	24
AGD 175	3.63.175	175	74	115	189	150	50-80 / 37-60	-55° e + 90°	410	4	56	28

AGF

TRINCIATRICE PESANTE LATERALE/SBANCHINATRICE

GEO
Macchine Agricole

 50-80 HP



- Scatola ingranaggi in ghisa con ruota libera integrata
- Scatola esterna
- Lubrificazione scatola ingranaggi: olio SAE 90
- Potenza di trasmissione applicabile: 50 HP
- Rullo posteriore registrabile in altezza con raschia fango
- Tenditore cinghie registrabile
- Spessore fiancate laterali: 8 mm
- Slitte laterali registrabili
- Rotore con sistema di taglio lineare
- Controcoltello dentato, fissato con bulloni (sostituibile)
- Protezione anteriore combinata a catene e gomma
- Doppio pistone per movimentazione trincia
- Spostamento laterale idraulico con sistema anti shock
- Piedino di appoggio
- Valvola di blocco su pistone di alzata
- Sistema flottante terzo punto



Ø: 4-5 cm

UTENSILI



M16

A (mm)	R (mm)	(gr)
140	100	1200

ATTACCO TERZO PUNTO

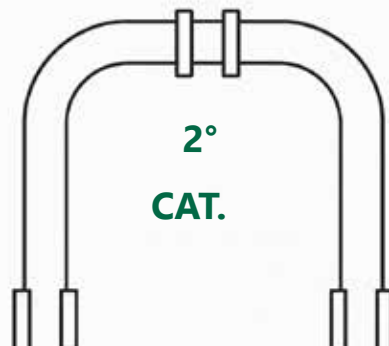

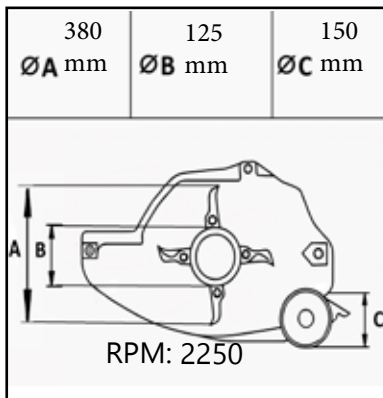

L=AGF 140: T-5x1700
 L= AGF 160: T-5x1700
 L= AGF 180: T-6x1700
 L= AGF 200: T-6x1700
 L= AGF 220: T-6X1700



ANTISHOCK



SISTEMA FLOTTANTE



SGANCIO DI SICUREZZA

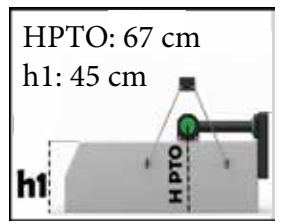

Mod.	M (cm)	N (cm)	O (cm)	P (cm)
AGF 140	94	47	235	93
AGF 160	114	47	255	93
AGF 180	134	47	275	93
AGF 200	154	47	295	93
AGF 220	164	58	284	62

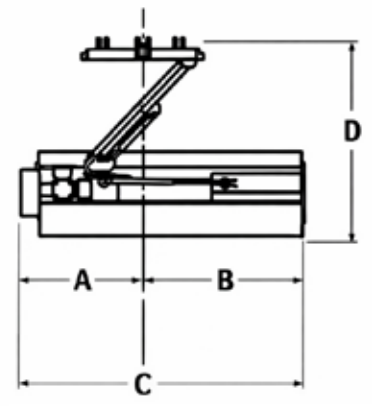
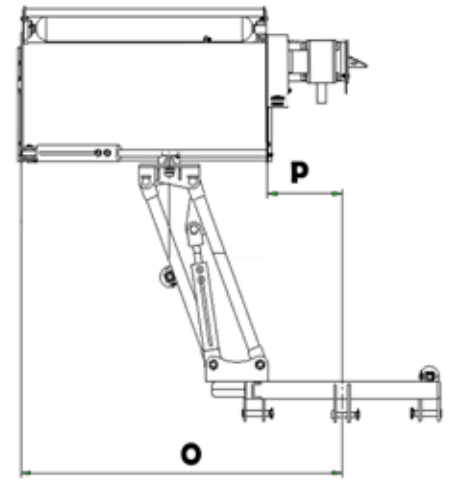
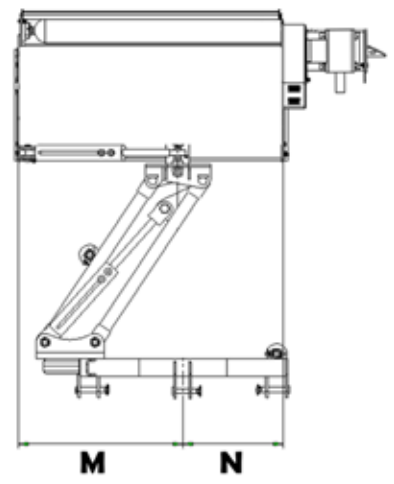

Mod.	Cod.	Larghezza di lavoro (cm)	A (cm)	B (cm)	C (cm)	D (cm)	HP/kW	Angolo	Kg	Cinghie	Martelli
AGF 140	3.37.140	140	86	94	180	158	50-80/37-60	.-55° e + 90°	550	3	12
AGF 160	3.37.160	160	86	114	200	158	50-80/37-60	.-55° e + 90°	590	3	14
AGF 180	3.37.180	180	86	134	220	158	50-80/37-60	.-55° e + 90°	640	3	16
AGF 200	3.37.200	200	86	154	240	158	50-80/37-60	.-55° e + 90°	680	4	18
AGF 220	3.37.220	220	96	164	260	158	50-80/37-60	.-55° e + 90°	710	4	22

AGFN

TRINCIATRICE PESANTE LATERALE/SBANCHINATRICE



 **50-80 HP**



- Scatola ingranaggi in ghisa con ruota libera integrata
- Scatola esterna
- Lubrificazione scatola ingranaggi: olio SAE 90
- Potenza di trasmissione: 50 HP (140-180) 80 HP (200-220)
- Rullo posteriore registrabile in altezza con raschia fango
- Tenditore cinghie registrabile
- Spessore fiancate laterali: 8 mm
- Slitte laterali registrabili
- Rotore con sistema di taglio elicoidale
- Controcoltello dentato
- Cofano apribile per facilitare le operazioni di manutenzione
- Doppio pistone per movimentazione trincia
- Spostamento laterale idraulico con sistema anti shock
- Piedino di appoggio
- Valvola di blocco su pistone di alzata
- Sistema flottante terzo punto
- Regolatore di flusso

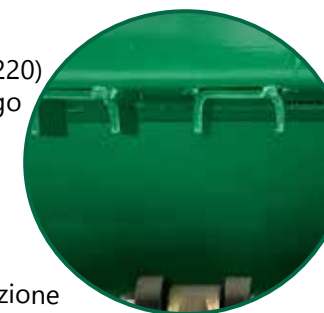

 **Ø: 4-6 cm**

UTENSILI		
		
A (mm)	R (mm)	(gr)
140	100	1200

ATTACCO TERZO PUNTO

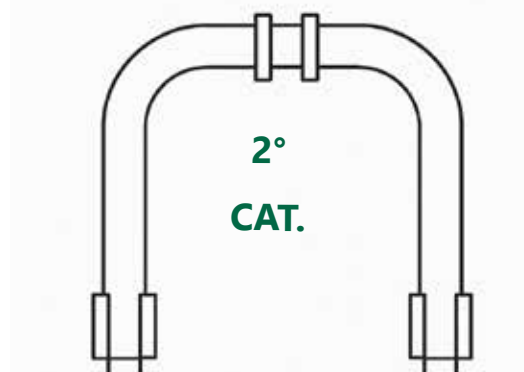

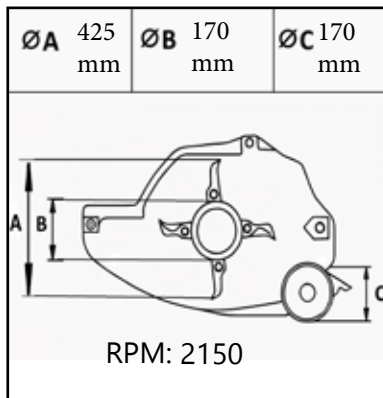

L=AGFN 140: T-5x1700
 L= AGFN 160: T-5x1700
 L= AGFN 180: T-6x1700
 L= AGFN 200: T-6x1700
 L= AGFN 220: T-6X1700

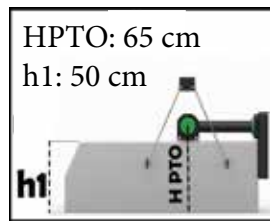
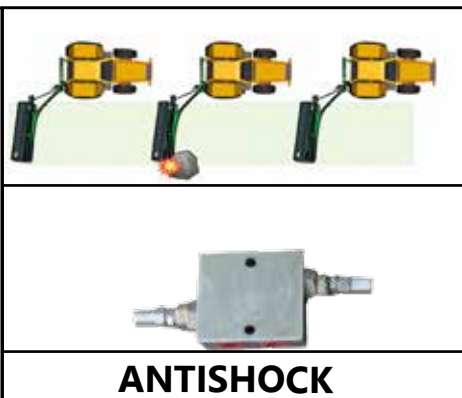

Mod.	M (cm)	N (cm)	O (cm)	P (cm)
AGFN 140	92	47	230	94
AGFN 160	102	47	250	94
AGFN 180	132	50	270	94
AGFN 200	149	50	290	91
AGFN 220	169	50	330	91

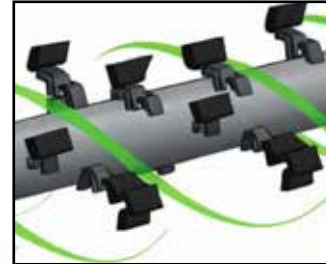

SISTEMA DI TAGLIO ELICOIDALE

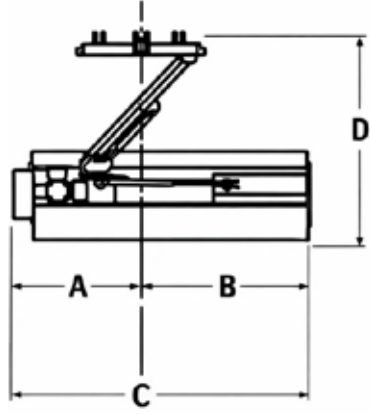
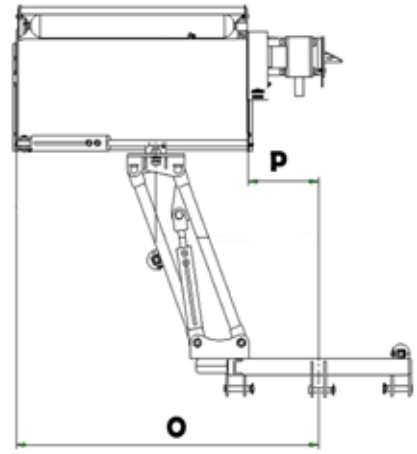
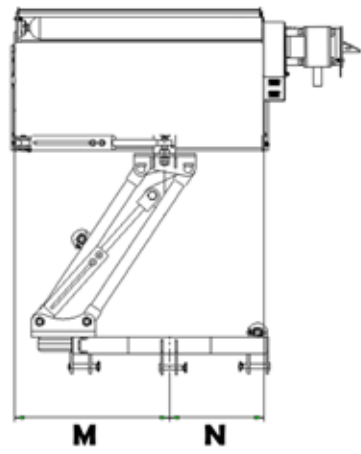

Mod.	Cod.	Larghezza di lavoro (cm)	A (cm)	B (cm)	C (cm)	D (cm)	HP/Kw	Angolo	Kg	Cinghie	Martelli
AGFN 140	3.37.140.3	140	98	92	190	166	50-80 / 37-60	.-55° e + 90°	568	4	12
AGFN 160	3.37.160.3	160	98	118	216	166	50-80 / 37-60	.-55° e + 90°	598	4	14
AGFN 180	3.37.180.3	180	98	132	230	166	50-80 / 37-60	.-55° e + 90°	654	4	16
AGFN 200	3.37.200.3	200	101	149	250	166	50-80 / 37-60	.-55° e + 90°	698	5	18
AGFN 220	3.37.220.3	220	101	169	270	166	50-80 / 37-60	.-55° e + 90°	728	5	22

AM

TRINCIATRICE CON BRACCIO



 25-60 HP

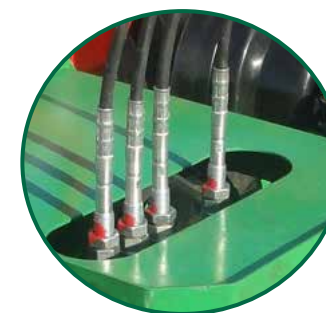
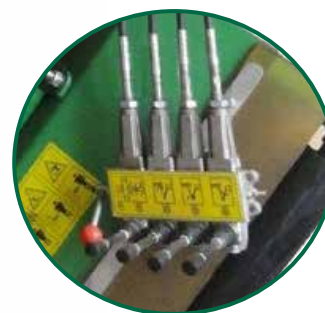

- Serbatoio indipendente 60 Lt
- Pompa in ghisa 25 cm³
- Motore 11 cc
- Comandi a cavi flessibili
- Doppio senso di rotazione
- Testata flottante 60-80-100 cm
- Trasmissione diretta al rotore
- Tenditori
- Filtro oleodinamico di ritorno
- Piedini di appoggio
- Testata con coltelli a cavalletto
- Carter protezione rotore

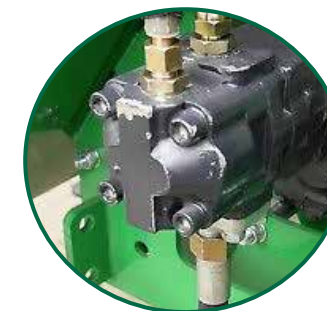





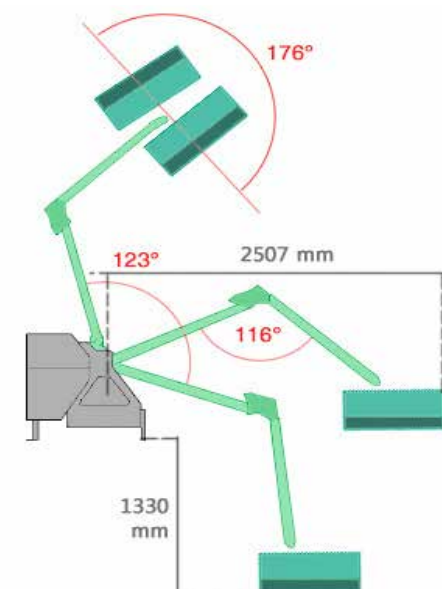
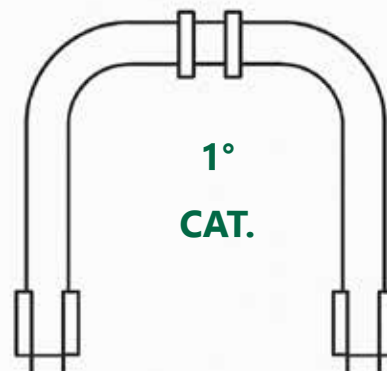



 Ø: 1-2 cm

ATTACCO TERZO PUNTO

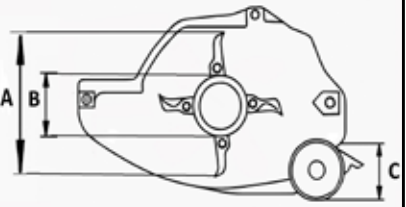

UTENSILI

  			
A (mm)	R (mm)	(gr)	
50	60	125	

$\varnothing A$ 265 mm	$\varnothing B$ 78 mm	$\varnothing C$ 100 mm	 L= AM 60: T-4X1000 L= AM 80: T-4X1000 L= AM 100: T-4X1000	60 cm	
 RPM: 2250				80 cm	
				100 cm	

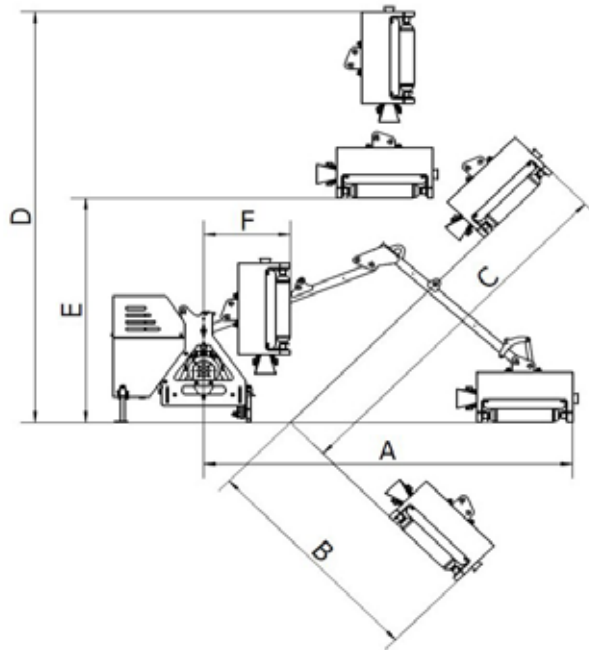

AM	A (cm)	B (cm)	C (cm)	D (cm)	E (cm)	F (cm)
AM60	255,5	163	256,5	298,5	163	60
AM80	275,5	183	276,5	318,5	163	60
AM100	295,5	203	296,5	338,5	163	60

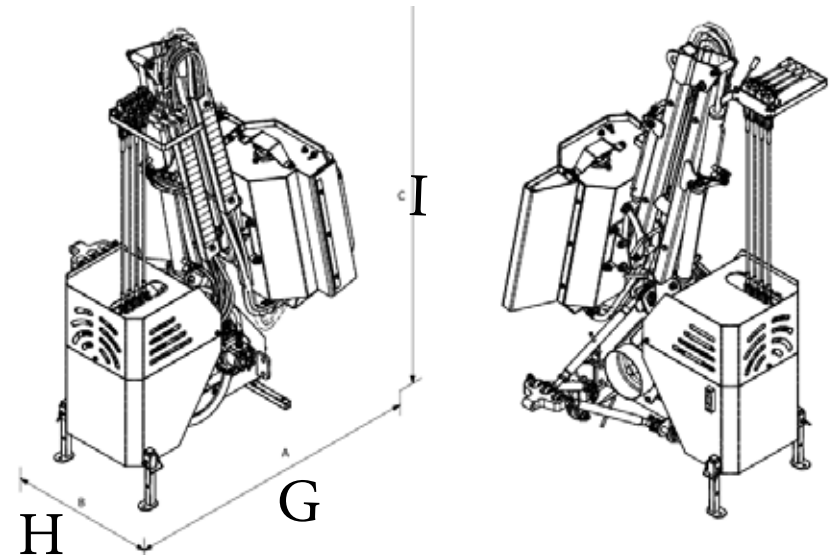

Mod.	Cod.	Larghezza di lavoro (cm)	G (cm)	H (cm)	I (cm)	Testata (cm)	Angolo di sollevamento	Kg	Capacità Olio	Coltelli
AM 60	3.90.60	60	125	95	209	60	176°	260	55	24
AM 80	3.90.80	80	125	95	209	80	176°	290	55	32
AM 100	3.90.100	100	125	95	209	100	176°	320	55	40

AM 125

TRINCIATRICE CON BRACCIO



 50-70 HP



 Ø: 1-2 cm





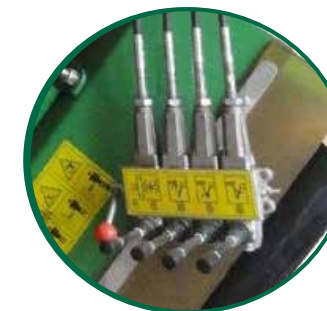

- Serbatoio indipendente 135 Lt
- Pompa in ghisa 41 cm³
- Motore 26 cc
- Comandi a cavi flessibili
- Doppio senso di rotazione
- Testata flottante 105 cm
- Tenditori
- Filtro oleodinamico di ritorno
- Piedini di appoggio
- Testata con coltelli
- Scambiatore di calore incluso
- Sospensione meccanica sul primo braccio
- Trasmissione diretta al rotore
- Carter protezione rotore

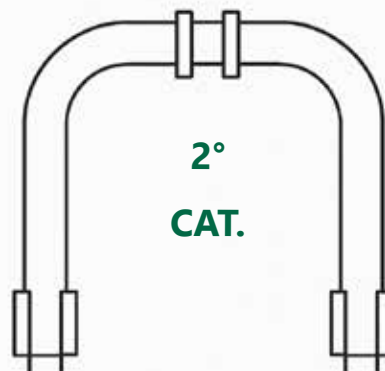

ATTACCO TERZO PUNTO



UTENSILI

  		
A (mm)	R (mm)	
45	100	275

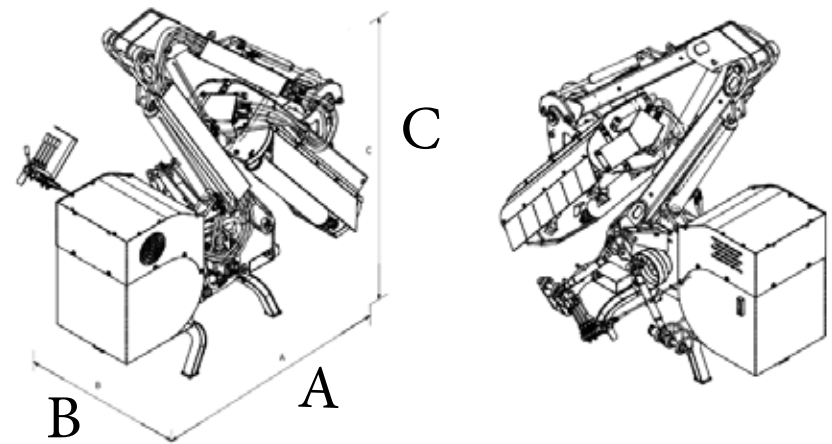
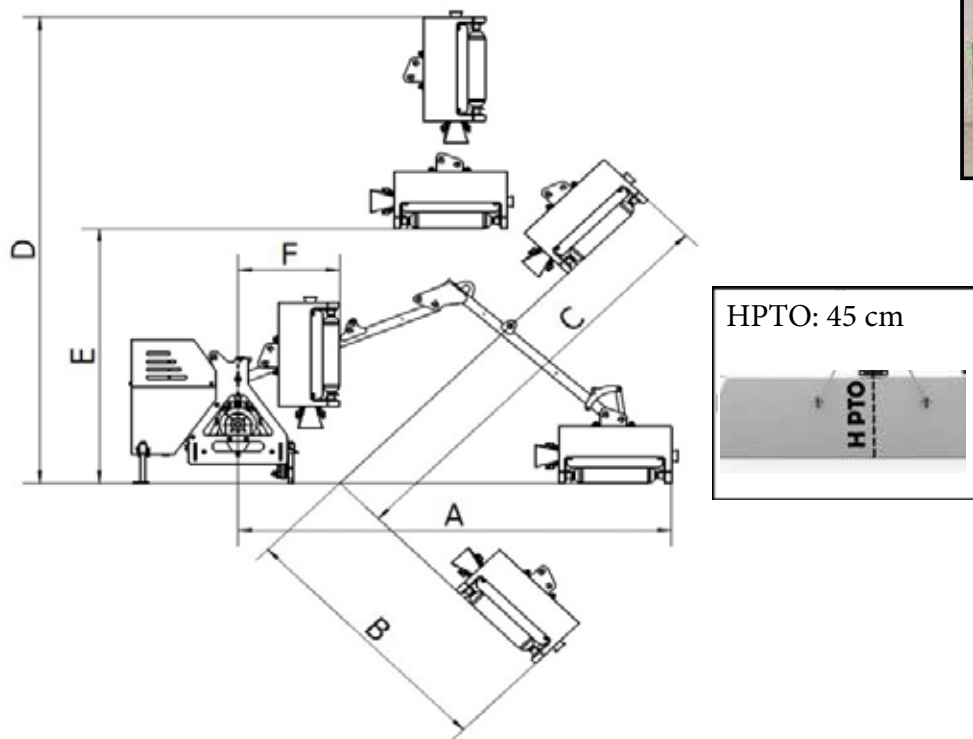
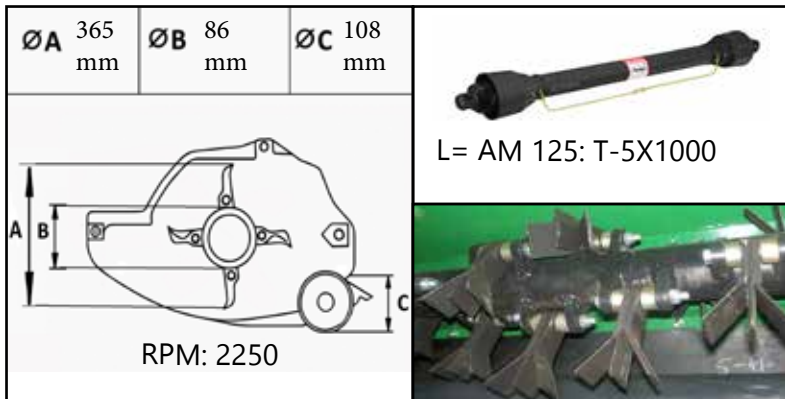

Mod.	A (cm)	B (cm)	C (cm)	D (cm)	E (cm)	F (cm)
AM 125	4519	3106	4550	4781	2550	921

Mod.	Cod.	Larghezza di lavoro (cm)	A (cm)	B (cm)	C (cm)	Testata (cm)	HP/Kw	Angolo di sollevamento	Kg	Capacità Olio	Coltelli
AM 125	3.91.125	105	125	56	249	105	50-70	176°	670	135	32

AMD

TRINCIASIEPI CON BRACCIO



 **25-60 HP**

 **Ø: 2-3 cm**



- Serbatoio indipendente 60 Lt
- Pompa in ghisa 25 cm³
- Motore orbitale 50 cc
- Comandi a cavi flessibili
- Doppio senso di rotazione
- Testata decespugliatrice 120-150-180 cm
- Tenditori
- Filtro oleodinamico di ritorno
- Piedini di appoggio

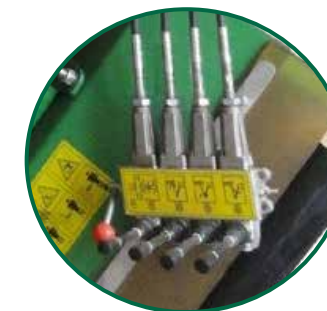

ATTACCO TERZO PUNTO

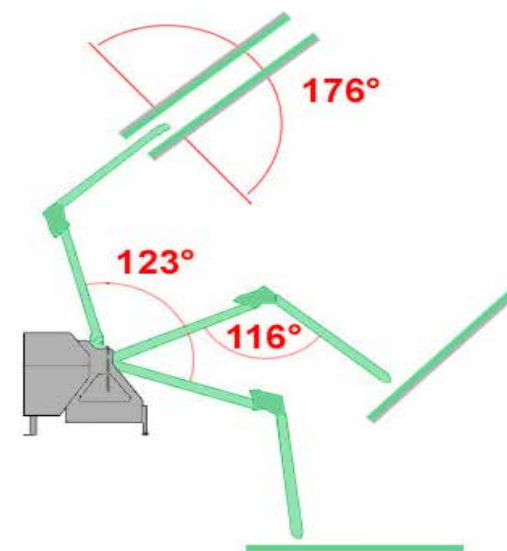
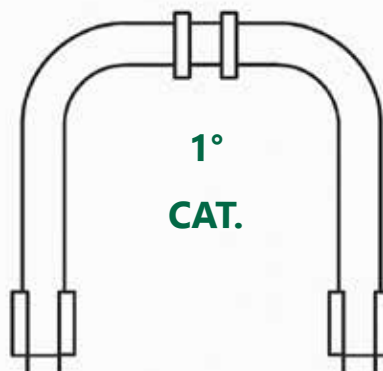

120 Cm



150 Cm

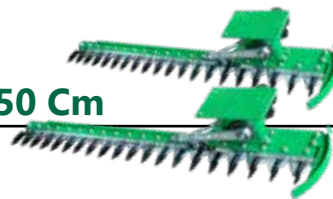

180 Cm



L= AMD 120: T-4X1000

L= AMD 150: T-4X1000

L= AMD 180: T-4X1000

HPTO: 35 cm

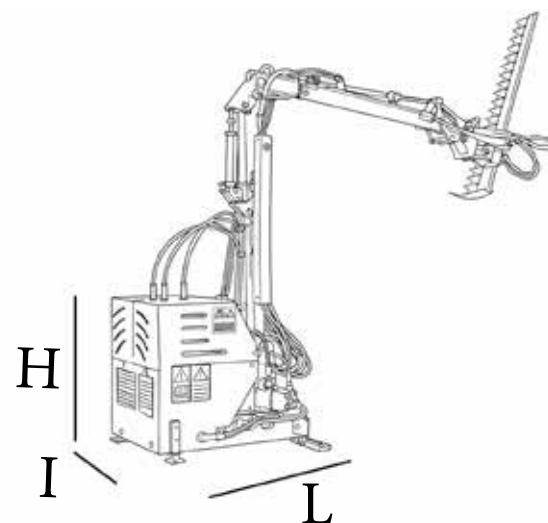
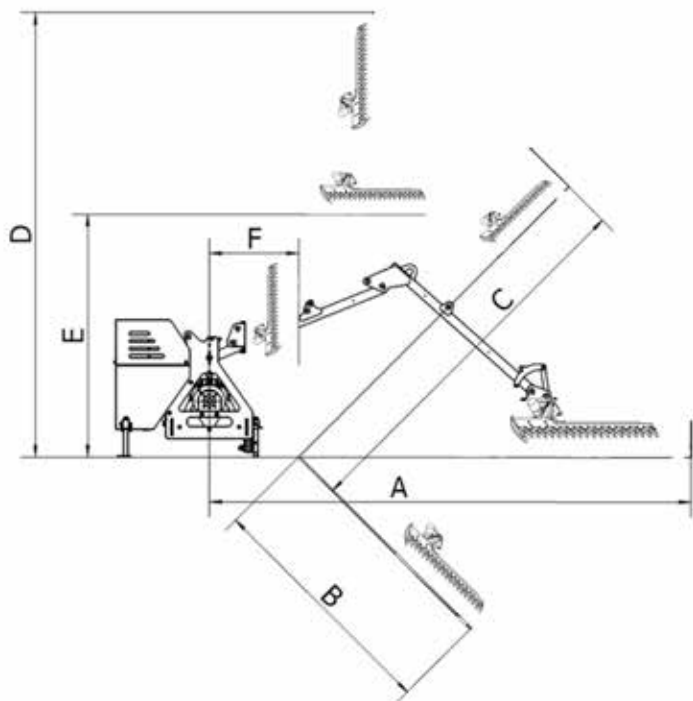
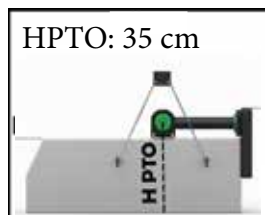

AMD	A (cm)	B (cm)	C (cm)	D (cm)	E (cm)	F (cm)
AMD 120	315,5	223	316,5	358,5	163	50
AMD 150	345,5	253	346,5	388,5	163	50
AM 180	375,5	283	376,5	418,5	163	50

Mod.	Cod.	Larghezza di lavoro (cm)	I (cm)	L (cm)	H (cm)	Testata (cm)	HP/kW	Kg	Lt
AMD 120	3.10.120	120	125	95	209	120	25-60/18-44	217	55
AMD 150	3.10.150	150	125	95	209	150	25-60/18-44	254	55
AMD 180	3.10.180	180	125	95	209	180	25-60/18-44	288	55

BRC

TRINCIASIEPI CON BRACCIO



 **15-50HP**



- Posizionamento macchina operatrice: frontale e posteriore
- Motore orbitale 50 cc
- Distributore con comandi
- Doppio senso di rotazione
- Testata decespugliatrice 120-150-180 cm
- Sospensione meccanica sul primo braccio
- Flusso idraulico minimo 25 Lt/min
- Valvole di blocco su cilindri



 **Ø: 2-3 cm**

ATTACCO TERZO PUNTO

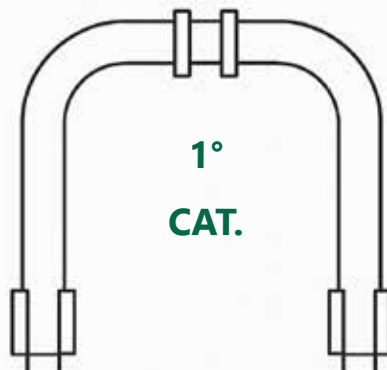

UTENSILI



Opzional
kit impianto idraulico
indipendente

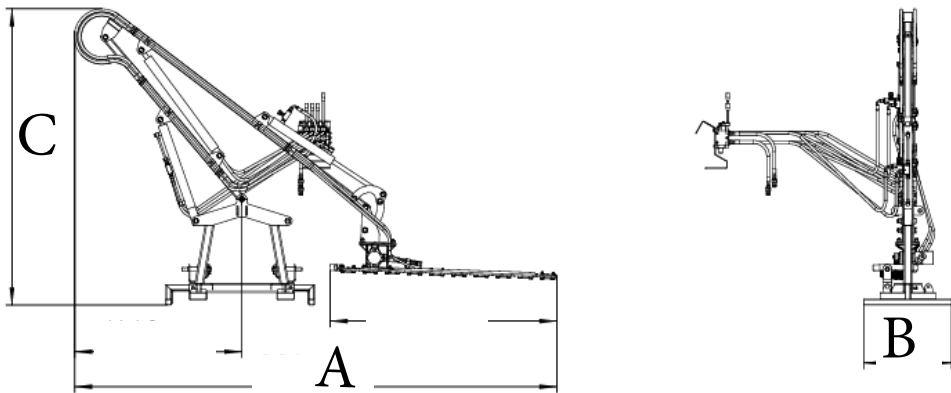
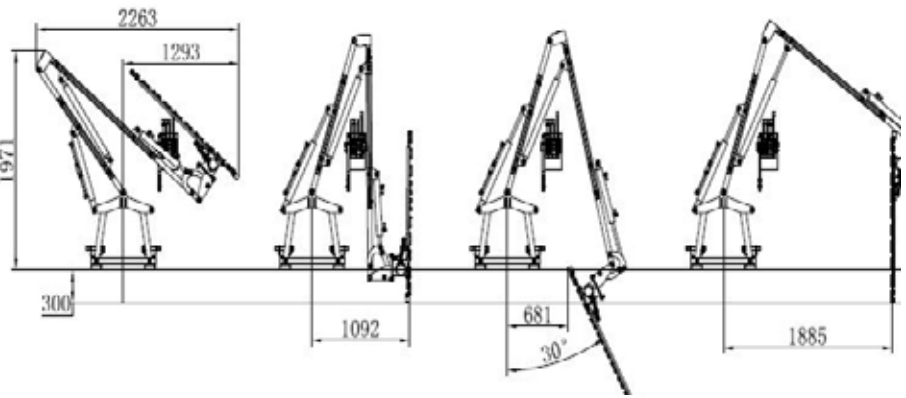
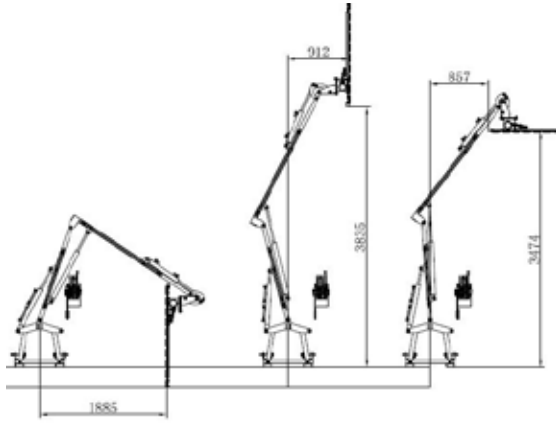

TRINCIATRICI CON BRACCIO

Mod.	Cod.	Larghezza di lavoro (cm)	A (cm)	B (cm)	C (cm)	Testata (cm)	HP/Kw	Kg	Lt/min (min)
BRC 120	3.12	120	300	60	203	120	15-40	240	25
BRC 150	3.13	150	330	60	203	150	25-50	250	25
BRC 180	3.14	180	360	60	203	180	25-50	260	25

AM-T

TESTATA TRINCIATRICE

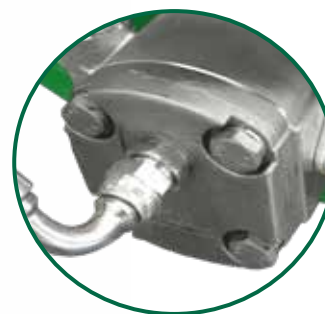
GEO[®]
 Macchine Agricole

- Motore orbitale 11 cc
- Doppio senso di rotazione
- Testata decespugliatrice 60-80-100 cm
- Flusso idraulico minimo 25 Lt/min
- Carter protezione motore
- Rullo autolivellante Ø 77 mm
- Rotore con coltelli a cavalletto



Ø: 1-2cm



UTENSILI

A (mm)	R (mm)	(gr)	
50	60	125	

Mod.	Cod.	Larghezza di lavoro (cm)	Lt/m	Kg	Coltelli
AM-T 60	3.95.60	60	30	62	24
AM-T 80	3.95.80	80	30	74	32
AM-T100	3.95.100	100	30	88	40



- Motore orbitale 50 cc
- Doppio senso di rotazione
- Testata decespugliatrice 120-150-180 cm
- Flusso idraulico minimo 25 Lt/min
- Molla antiurto regolabile
- Piastra di attacco a 4 fori
- Slitta laterale
- Controltello fisso



Ø: 2-3 cm

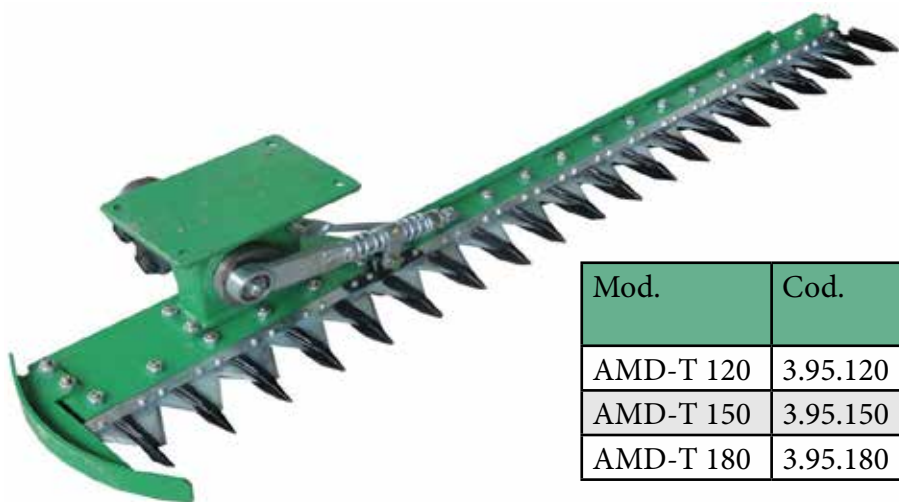

Mod.	Cod.	Larghezza di lavoro (cm)	Lt/m	Kg
AMD-T 120	3.95.120	120	21	40
AMD-T 150	3.95.150	150	21	45
AMD-T 180	3.95.180	180	23	50

UTENSILI



BJ

TRINCIASIEPI PER CARICATORE

GEO[®]
Macchine Agricole



Ø: 2-3 cm

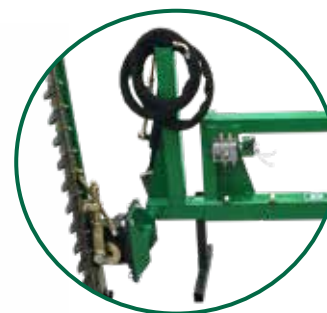

- Motore orbitale 50 cc
- Doppio senso di rotazione
- Testata decespugliatrice 120-150-180 cm
- Flusso idraulico minimo 25 Lt/min
- Piedini di appoggio
- Regolatori di flusso
- Elettrovalvola 12 V per selettore idraulico
- Spostamento laterale meccanico
- Attacco universale Euro I / Opzionale Attacco a 3° punto
- Attacco tramite forche muletto

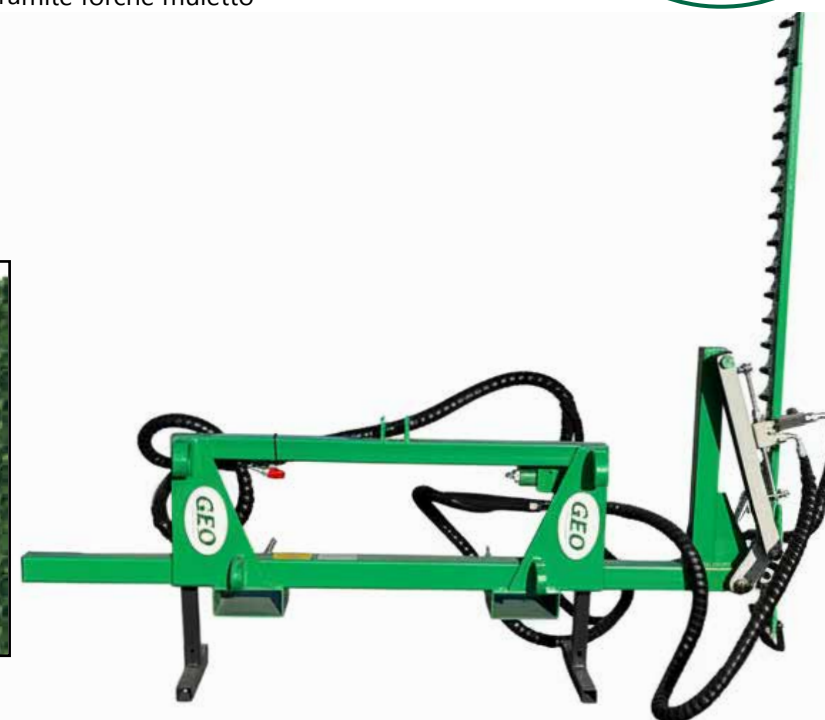

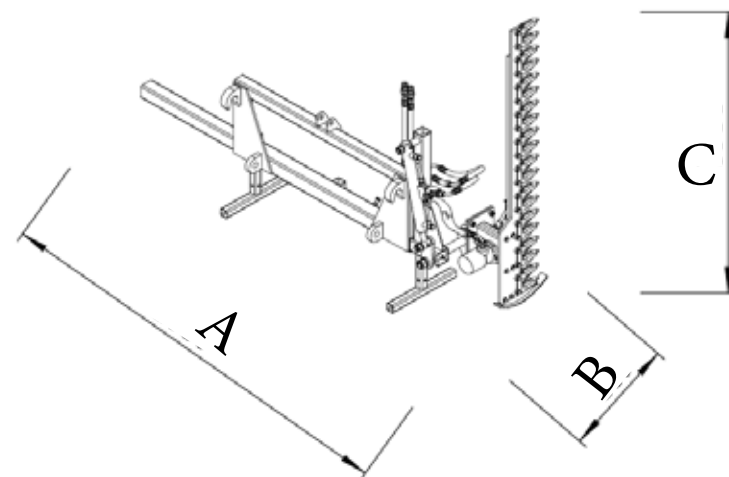
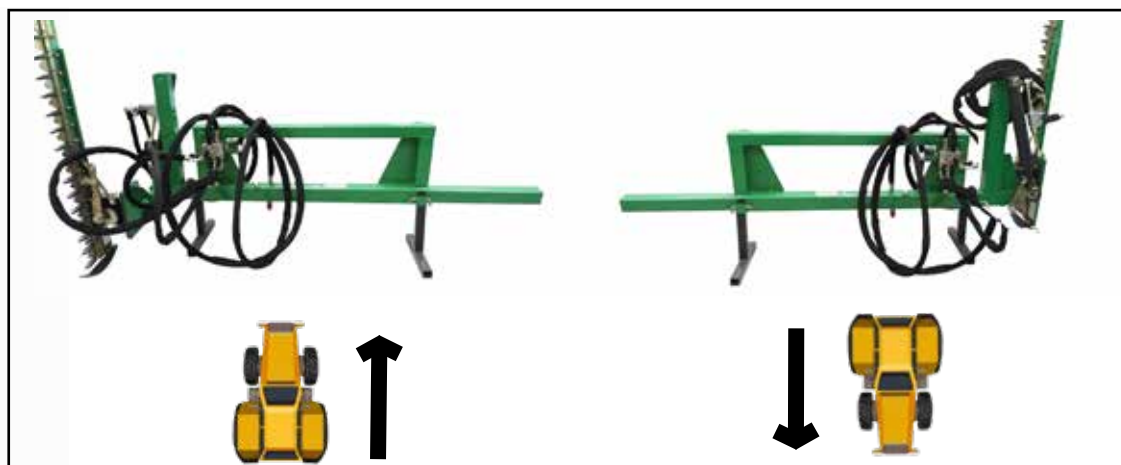
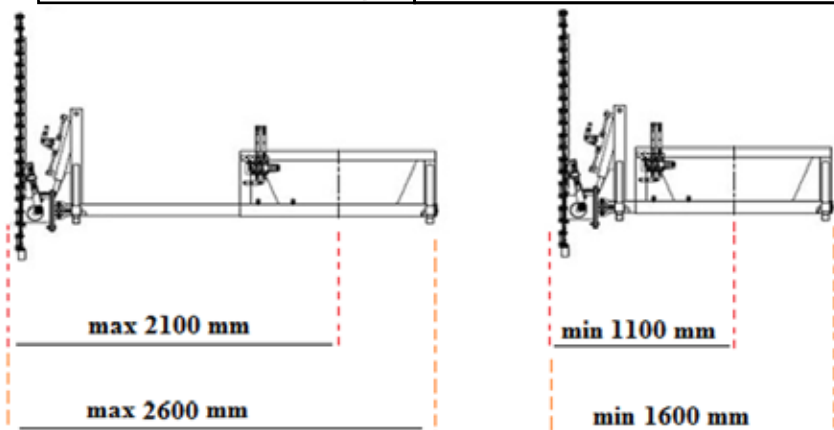

Mod.	Cod.	Lunghezza barra (cm)	Inclinazione	A (cm)	B (cm)	C (cm)	Kg	Lt/min
BJ 120	19.13.120	120	-50° +90°	208	61	126	152	30
BJ 150	19.13.150	150	-50° +90°	208	61	156	162	30
BJ 180	19.13.180	180	-50° +90°	208	61	186	172	30

KM100

PIATTO TOSAERBA ZINCATO



 20-40 HP

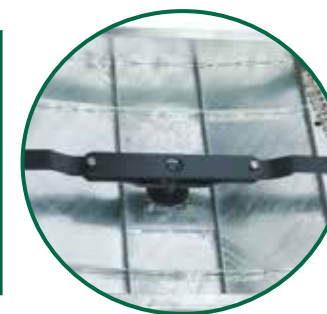

- Robusta scatola ingranaggi in ghisa
- Tosaerba ad asse verticale
- Struttura zincata
- Paratie a catene anteriori e posteriori
- Slitte laterali
- Coppia di lame snodate
- Terzo punto flottante
- Olio consigliato SAE90 o EP00

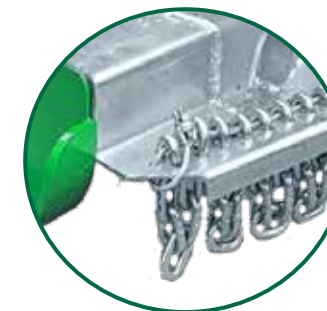

ATTACCO TERZO PUNTO

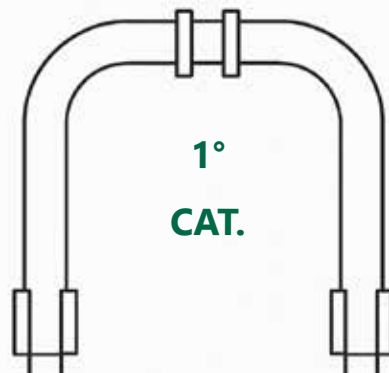

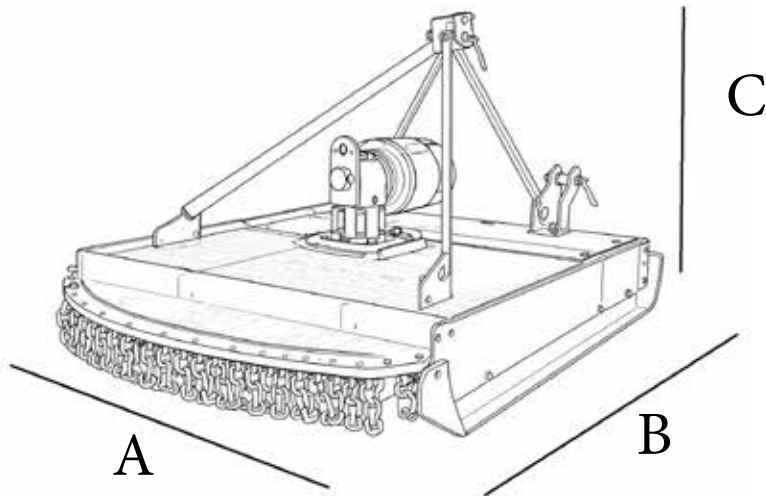
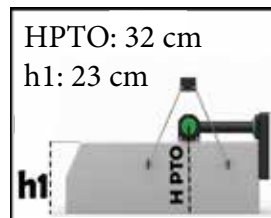
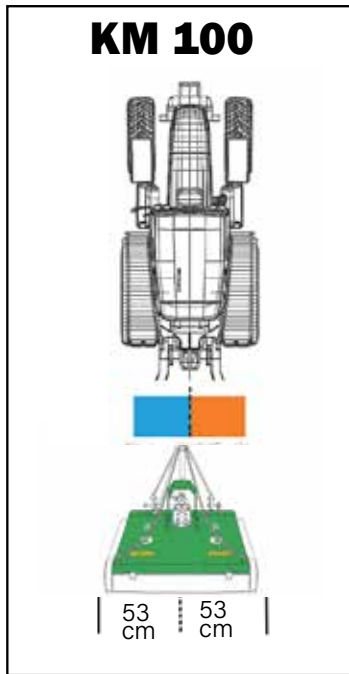

Mod.	Cod.	Larghezza di lavoro (cm)	A (cm)	B (cm)	C (cm)	HP/Kw	Kg	Lame
KM100	6.11.100	100	106	104	132	20-40 / 14-29	122	2

TM

TOSAERBA AD ASSE VERTICALE

GEO[®]
Macchine Agricole



 30-50 HP

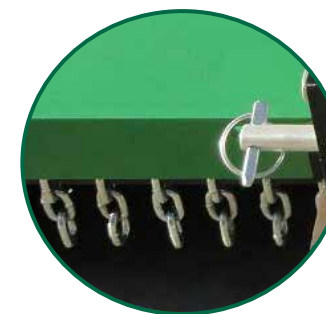

- Robusta scatola ingranaggi in ghisa
- Tosaerba ad asse verticale
- Paratie a catene posteriori
- Slitte laterali regolabili
- Coppia di lame snodate
- Terzo punto snodabile
- Olio consigliato SAE90
- Ruota di appoggio posteriore pivottante



ATTACCO TERZO PUNTO

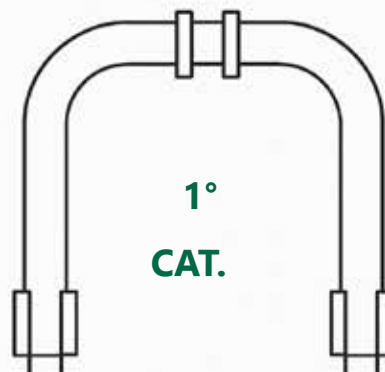

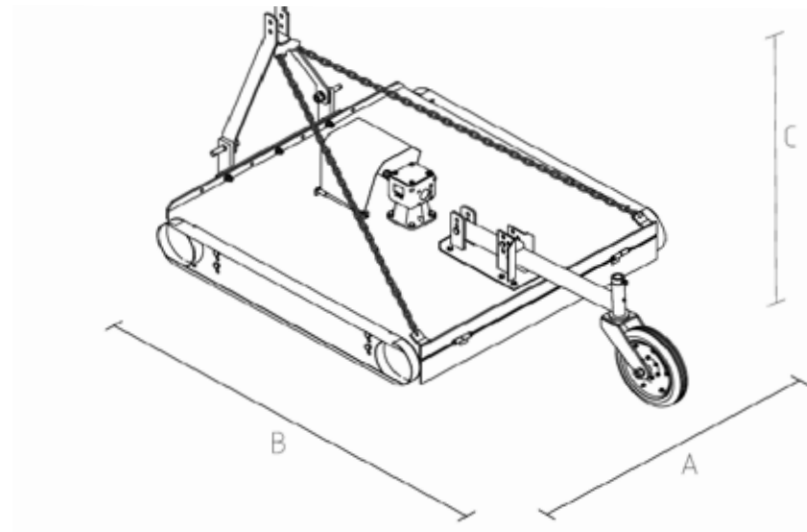
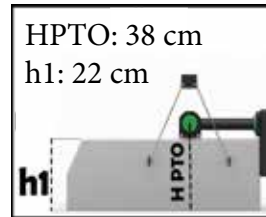
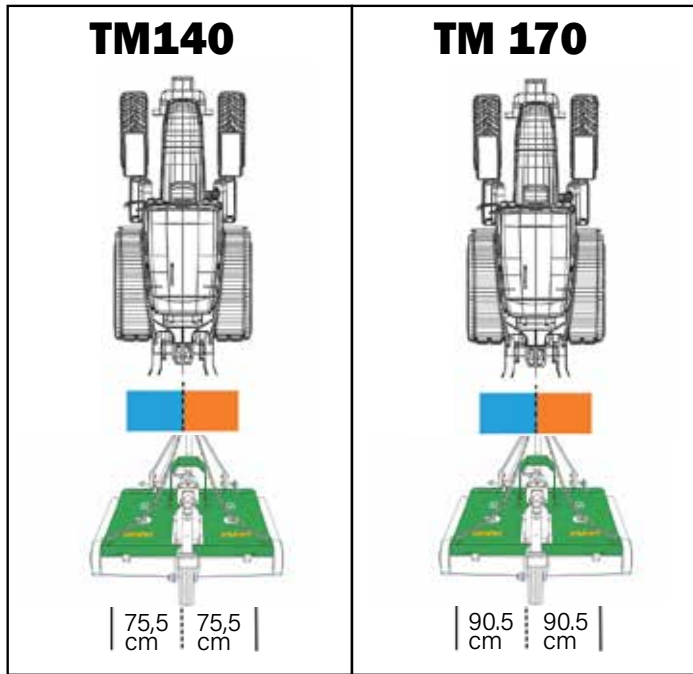

Mod.	Cod.	Larghezza di lavoro (cm)	A (cm)	B (cm)	C (cm)	HP/Kw	Coltelli	Kg	Lame
TM 140	7.12.140	140	151	246	95	30-50 / 22-37	2	240	2
TM 170	7.12.170	170	181	276	95	30-50 / 22-37	2	260	2

DM SILVER

PIATTO TOSAERBA ZINCATO CON RUOTE PIVOTTANTI



14-50 HP

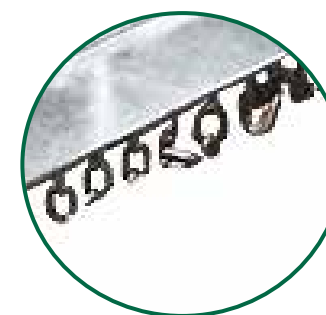

- Telaio zincato rinforzato
- Robusta scatola ingranaggi in ghisa
- Ruote pivotanti regolabili in altezza
- 2 cinghie dentate ad alta resistenza
- Altezza di taglio 2,5-10 cm
- Altezza di taglio regolabile tramite boccole ruote
- Telaio rinforzato 4 mm
- Forcella porta ruota stampata
- Catene posteriori
- Punto di ingrassaggio centralizzato
- Olio consigliato SAE90
- Terzo punto flottante

ATTACCO TERZO PUNTO

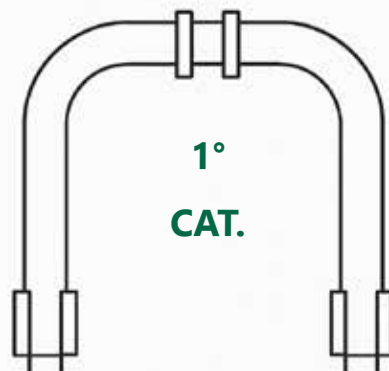

UTENSILI	
	LAMA STANDARD
	KIT MULCHING OPTIONAL





H: 2,5-10 cm



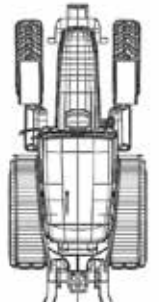
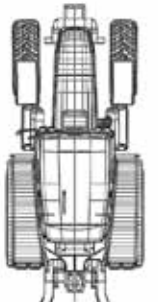
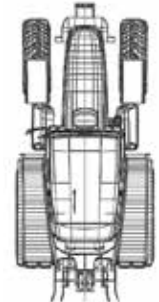

L= DM 120 SILVER: T-4X1000
 L= DM 150 SILVER: T-4X1000
 L= DM 180 SILVER: T-4X1000



DM 120	DM 150	DM 180
		
		
60 cm 60 cm	75 cm 75 cm	90 cm 90 cm

HPTO: 45 cm
 h1: 47 cm

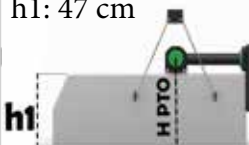
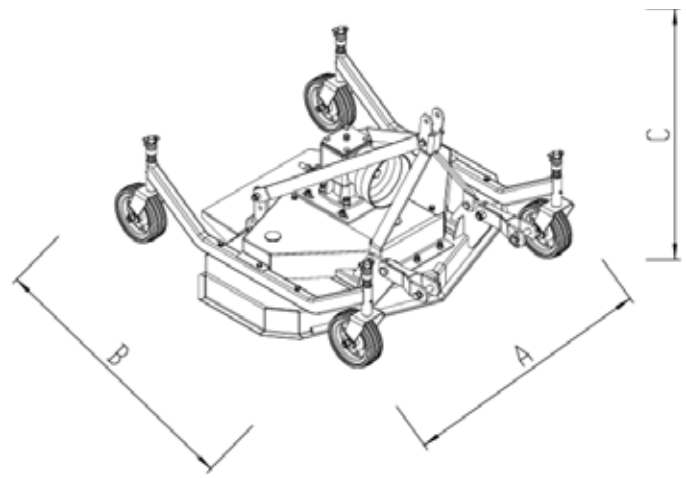



Mod.	Cod.	Larghezza di lavoro (cm)	A (cm)	B (cm)	C (cm)	HP/Kw	Kg	Diametro rotore	Coltelli
DM 120 Silver	16.17.120	120	126	140	84	14-40/10-30	195	8x21/ 3x8	3
DM 150 Silver	16.18.150	150	156	150	84	14-40/10-30	220	8x21/ 3x8	3
DM 180 Silver	16.19.180	180	186	150	84	14-15/10-37	250	8x21/ 3x8	3

DM 210N

PIATTO TOSAERBA ZINCATO CON RUOTE PIVOTTANTI

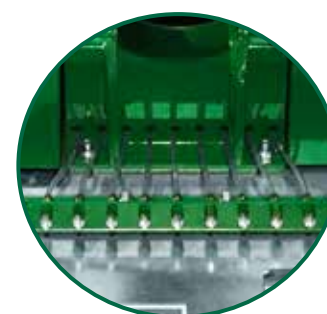
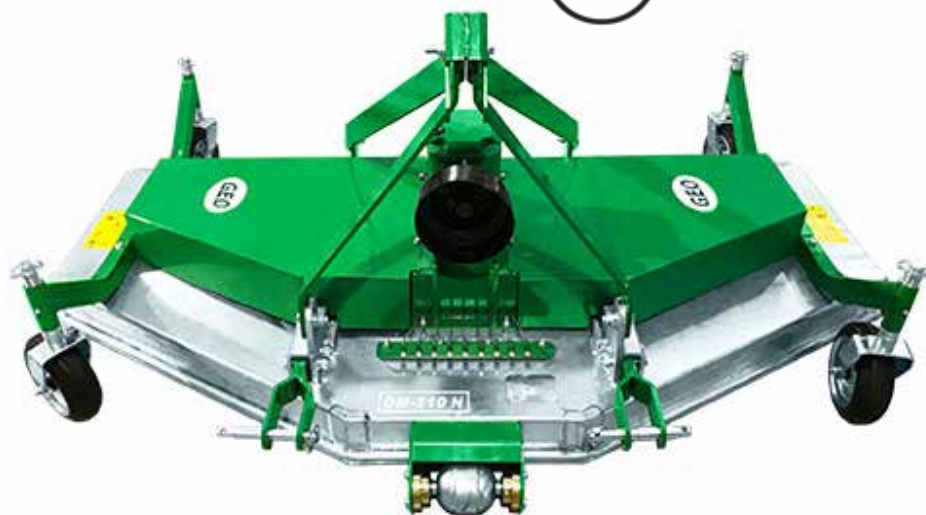
 40-70 HP



- Telaio zincato rinforzato
- Robusta scatola ingranaggi in ghisa
- Ruote pivotanti regolabili in altezza con molle
- 2 cinghie dentate ad alta resistenza
- Altezza di taglio 10-24-30-40-70 mm
- Altezza di taglio regolabile tramite boccole ruote
- Telaio rinforzato 4 mm
- Forcella porta ruota stampata
- Paratie posteriori
- Punto di ingrassaggio centralizzato
- Olio consigliato SAE90
- Terzo punto flottante
- Ruotino anteriore di appoggio

ATTACCO TERZO PUNTO

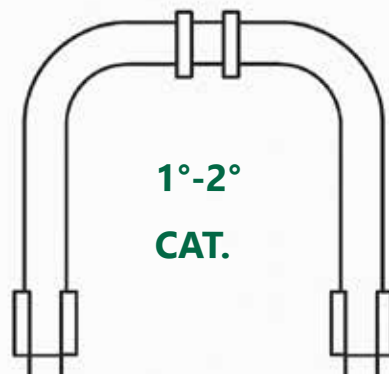

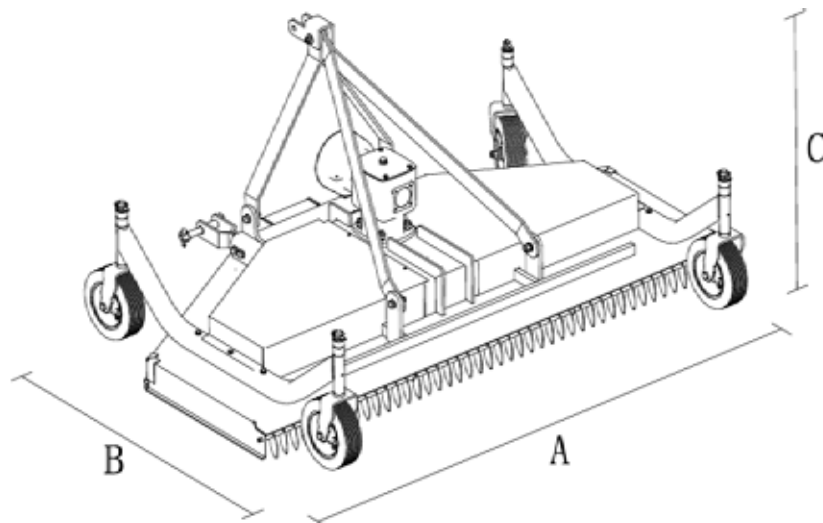
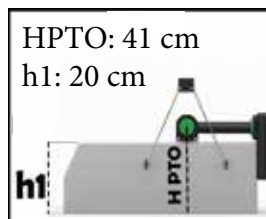
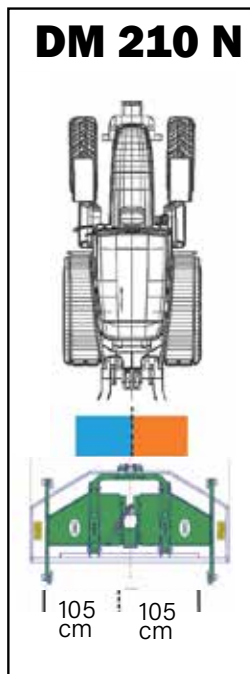

Mod.	Cod.	Larghezza di lavoro (cm)	A (cm)	B (cm)	C (cm)	HP/Kw	Kg	Lame
DM 210N	6.14.210.1	210	219	157	93	40-70/29-52	352	5

DM3 210

PIATTO TOSAERBA CON TRASLATORE IDRAULICO

 **40-70 HP**

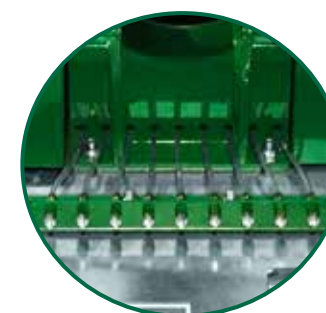
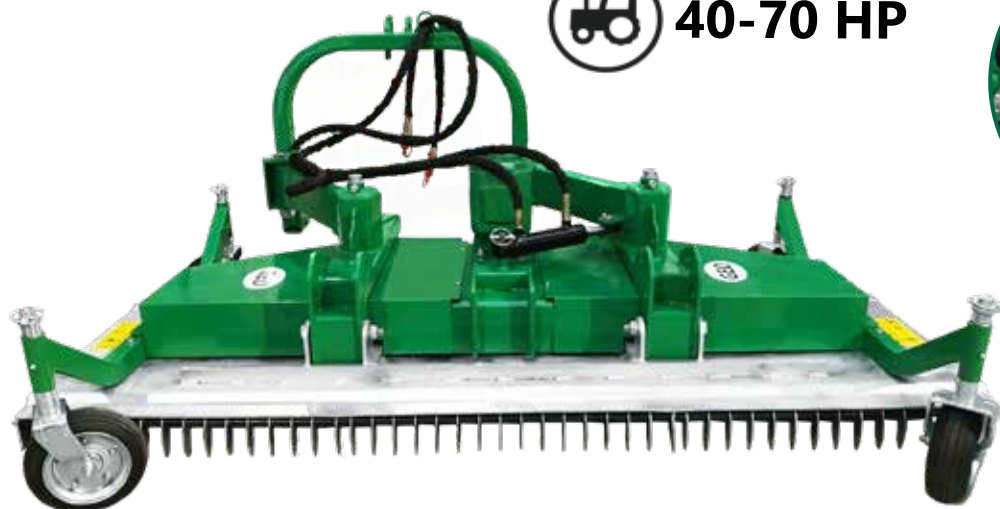

- Telaio zincato rinforzato
- Robusta scatola ingranaggi in ghisa
- Ruote pivotanti regolabili in altezza con molle
- 2 cinghie dentate ad alta resistenza
- Altezza di taglio 10-24-30-40-70 mm
- Altezza di taglio regolabile tramite boccole ruote
- Telaio rinforzato 4 mm
- Forcella porta ruota stampata
- Paratie posteriori
- Scarico posteriore
- Pistone idraulico di spostamento
- Spostamento idraulico di 60 cm
- Punto di ingrassaggio centralizzato
- Olio consigliato SAE90
- Ruotino anteriore di appoggio



ATTACCO TERZO PUNTO

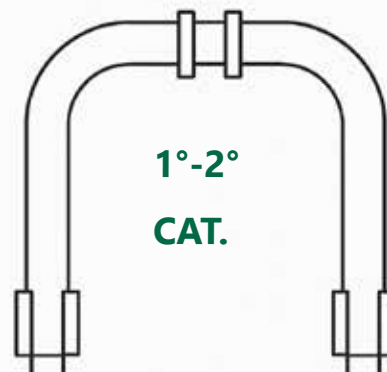

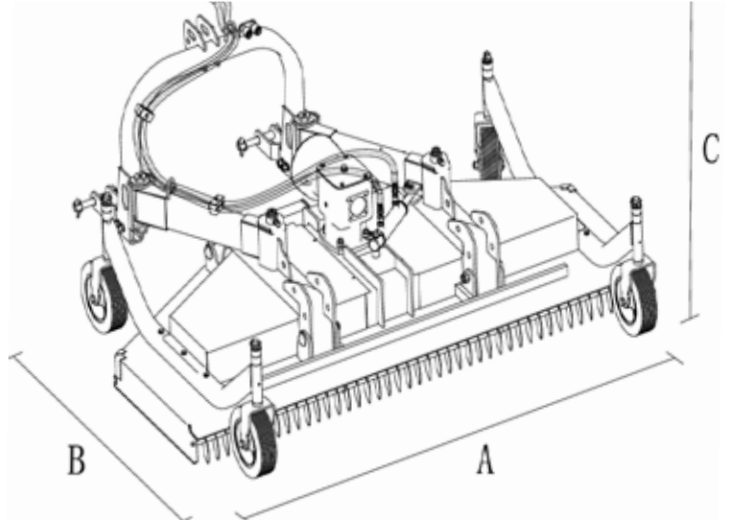
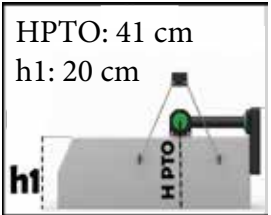
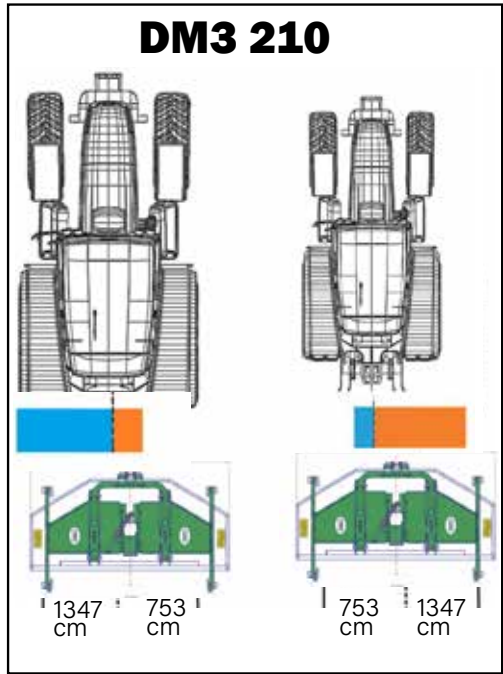

Mod.	Cod.	Larghezza di lavoro (cm)	A (cm)	B (cm)	C (cm)	HP/Kw	Kg	Lame
DM3 210	6.12.210	210	219	175	90	40-70/29-52	440	5

DISK 650

DISCO IDRAULICO CON TELAIO 3° PUNTO

 35-85 HP



- Motore idraulico GR2 14cc
- Molla antiurto con regolazione manuale
- Molla di regolazione dell'inclinazione
- Disco da 650 mm
- Flusso idraulico minimo 25 Lt/min
- Ruote in ferro
- Piedino di appoggio
- Spostamento laterale idraulico
- Doppia lama pivottante
- Regolazione in altezza con sistema flottante (20 cm)



ATTACCO TERZO PUNTO

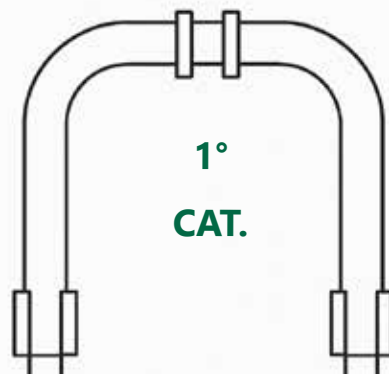

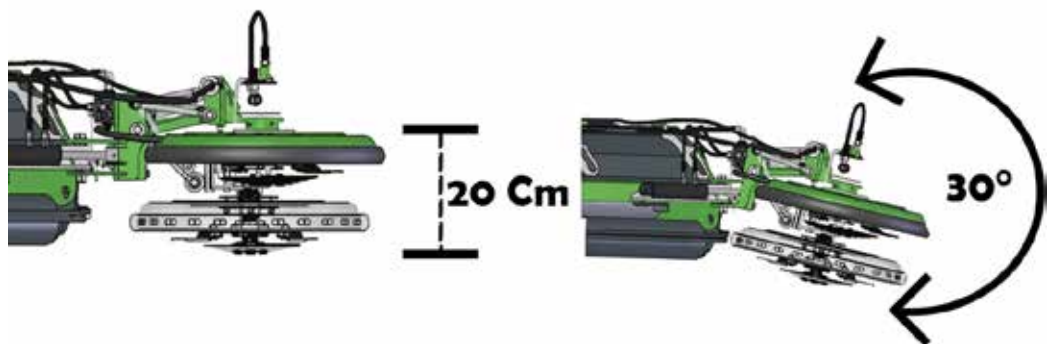

Caratteristica	Unità metrica
Larghezza di taglio	650.0 mm
Peso	46 kg
Velocità rotazione lame	2300 rpm @t 30 Lt
Flusso ottimale dell'olio	30 l/min Max

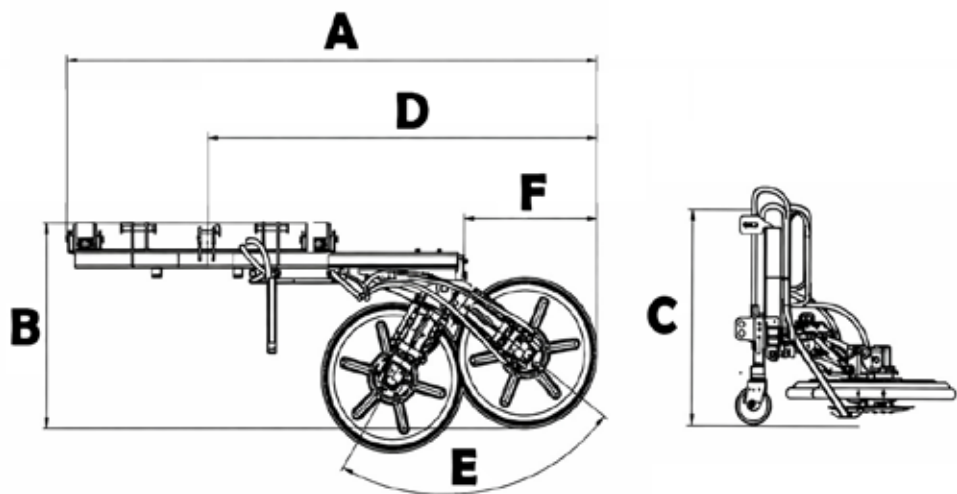

Mod.	Cod.	Diametro disco Ø	A (cm)	B (cm)	C (cm)	D (Cm)	E (°)	F (Cm)	Lame
DISK 650	21.650	65 cm	214	95	94	150-193	83°	66	2

GB

PIATTO TOSAERBA CON DISCO

GEO[®]
Macchine Agricole

 25-60 HP



- Robusta scatola ingranaggi in ghisa
- Ruote pivotanti regolabili in altezza
- 3 cinghie dentate ad alta resistenza
- Altezza di taglio 10-24-30-40-70 mm
- Altezza di taglio regolabile tramite boccole ruote
- Telaio rinforzato 4 mm
- Paratie a catena anteriori
- Scarico posteriore
- Disco interfilare diametro 650 mm
- Molla meccanica regolabile
- Olio consigliato SAE90
- Rullo posteriore regolabile
- Sportelli apribili per ingrassaggio
- Bracci flottanti



UTENSILI



ATTACCO TERZO PUNTO

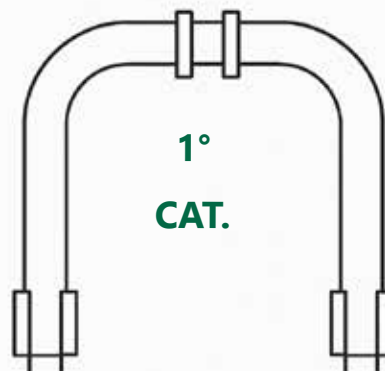



H: 1-7 cm



L= GB 120: T-4X1000
L= GB 150: T-4X1000
L= GB 180: T-4X1000

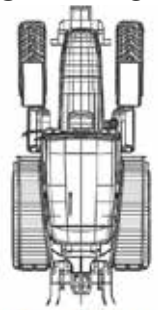
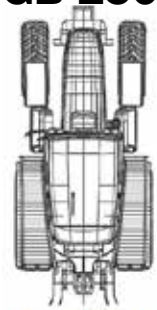
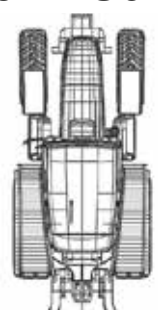

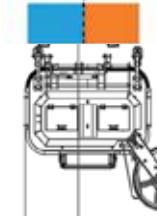
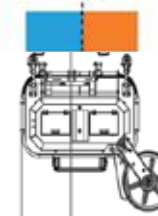
GB 120	GB 150	GB 180
		
		
95 cm 95 cm	105 cm 105 cm	117,5 cm 117,5 cm

HPTO: 45 cm
h1: 60 cm

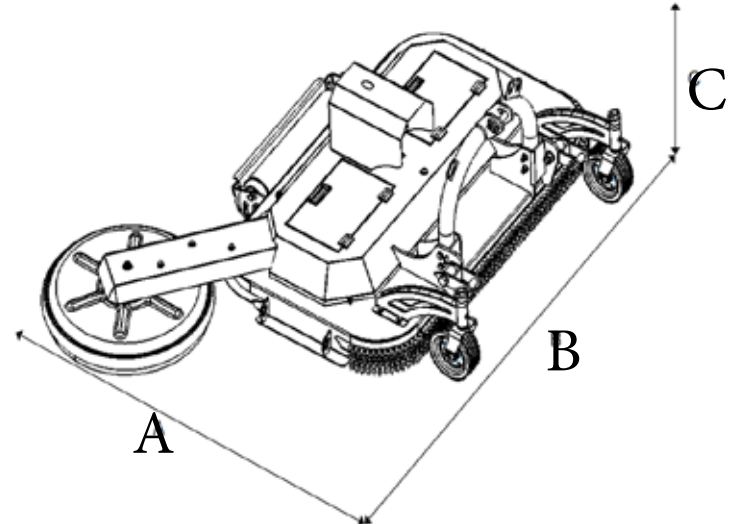



Mod.	Cod.	Larghezza di lavoro (cm)	A (cm)	B (cm)	C (cm)	Ø (mm)	HP/Kw	Kg	Lame
GB 120	21.120	115	183	190	74	65	25-50 / 18-37	210	6+2
GB 150	21.150	145	184	210	74	65	25-50 / 18-37	240	6+2
GB 180	21.180	175	185	235	74	65	30-60 / 22-45	270	6+2

GBH

PIATTO TOSAERBA CON DISCO E SPOSTAMENTO IDRAULICO

GEO[®]
Macchine Agricole

 25-60 HP



- Robusta scatola ingranaggi in ghisa
- Ruote pivottanti regolabili in altezza
- 3 cinghie dentate ad alta resistenza
- Altezza di taglio 10-24-30-40-70 mm
- Altezza di taglio regolabile tramite boccole ruote
- Telaio rinforzato 4 mm
- Paratie anteriori a catena
- Scarico posteriore
- Pistone idraulico di spostamento di 30 cm
- Disco interfilare diametro 650 mm
- Molla meccanica regolabile
- Olio consigliato SAE90
- Rullo posteriore regolabile
- Sportelli apribili per ingrassaggio
- Bracci flottanti



ATTACCO TERZO PUNTO

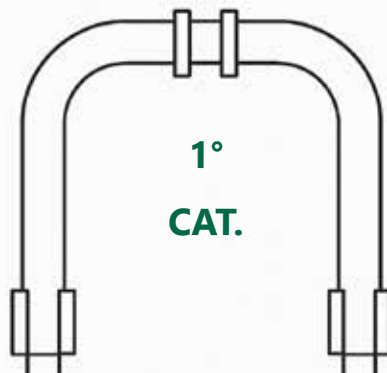

H: 1-7 cm





L= GBH 150: T-4X1000
L= GBH 180: T-4X1000



GB 150 H

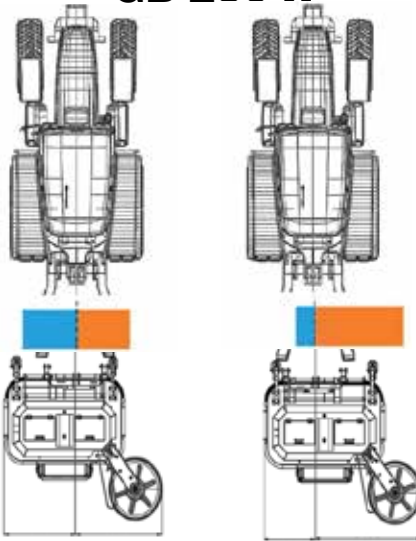

90 cm 114 cm 60 cm 144 cm

GB 180 H

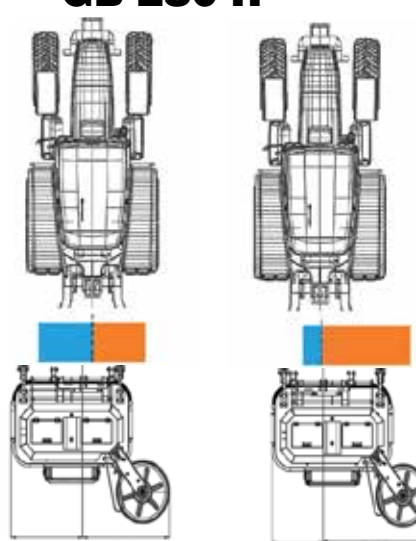

105 cm 128 cm 75 cm 158 cm

HPTO: 45 cm
h1: 60 cm

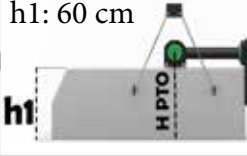
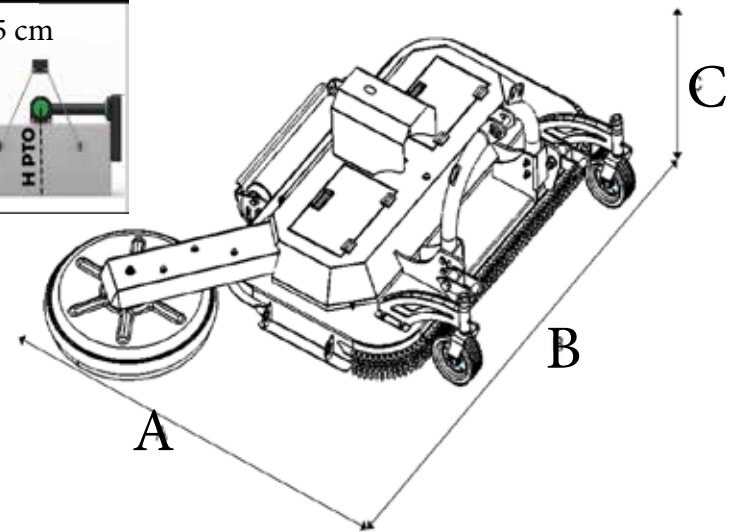



GBH	Cod.	Larghezza di lavoro (cm)	A (cm)	B (cm)	C (cm)	(mm)	HP/Kw	Kg	Lame
GB 150 H	21.150H	145	182	209	74	65	25-50 / 18-37	266	6+2
GB 180 H	21.180H	175	180	237	74	65	30-60 / 22-45	286	6+2

GB 120 DD

PIATTO TOSAERBA FISSO CON DOPPIO DISCO A MOLLA

GEO[®]
Macchine Agricole

 **30-80 HP**



- Robusta scatola ingranaggi in ghisa
- Ruote pivotanti regolabili in altezza
- 4 cinghie dentate ad alta resistenza
- Altezza di taglio 10-24-30-40-70 mm
- Altezza di taglio regolabile tramite boccole ruote
- Telaio rinforzato 4 mm
- Paratie anteriori a catena
- Scarico posteriore
- Pistone idraulico di spostamento
- Doppio disco interfilare diametro 650 mm
- Disco interfilare con molla meccanica regolabile
- Olio consigliato SAE90

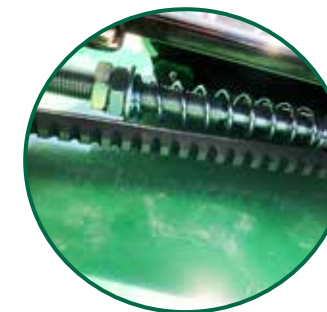

ATTACCO TERZO PUNTO

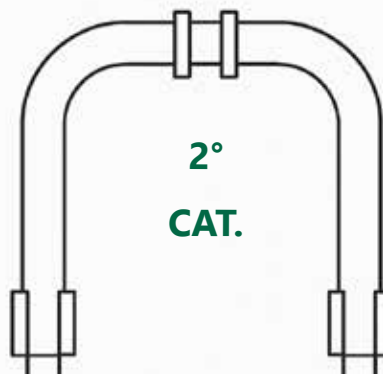

H: 1-7 cm





L= GB 120 DD: T-4X1000
 L= GB 150 DD: T-4X1000
 L= GB 180 DD: T-4X1000

GB 120 DD

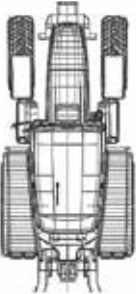
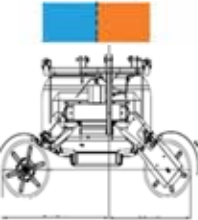
124 cm 124 cm

HPTO: 45 cm
 h1: 60 cm

Mod.	Cod.	Larghezza lavoro (cm)	A (cm)	B (cm)	C (cm)	2 (mm)	HP/Kw	Kg	Lame
GB 120 DD	21.120DD	120	174	248	74	65	30-80 / 22-59	318	6+2+2

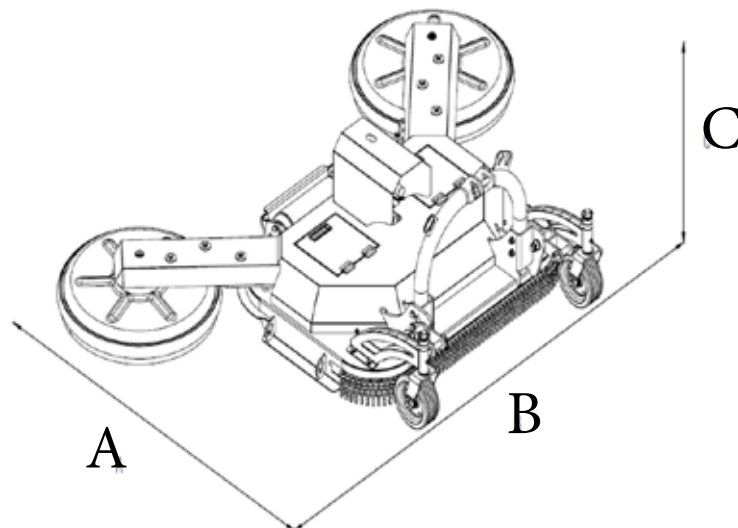
GB 150/180 DD

PIATTO TOSAERBA E DOPPIO DISCO CON TASTATORE IDRAULICO

 30-80 HP



- Robusta scatola ingranaggi in ghisa
- Ruote pivotanti regolabili in altezza
- 4 cinghie dentate ad alta resistenza
- Altezza di taglio 10-24-30-40-70 mm
- Altezza di taglio regolabile tramite boccole ruote
- Telaio rinforzato 4 mm
- Paratie anteriori a catena
- Scarico posteriore
- Pistone idraulico di spostamento di 35 cm
- Doppio disco interfilare diametro 650 mm
- Disco interfilare con tastatore idraulico
- Necessarie 4 prese idrauliche
- Olio consigliato SAE90



ATTACCO TERZO PUNTO

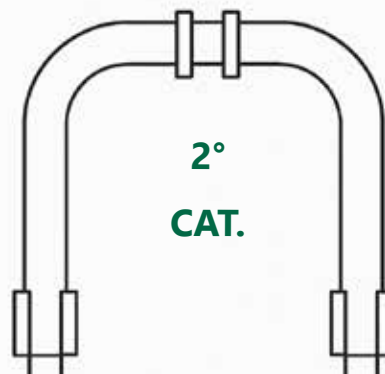

H: 1-7 cm



L= GB 120 DD: T-4X1000
 L= GB 150 DD: T-4X1000
 L= GB 180 DD: T-4X1000



GB 150 DD

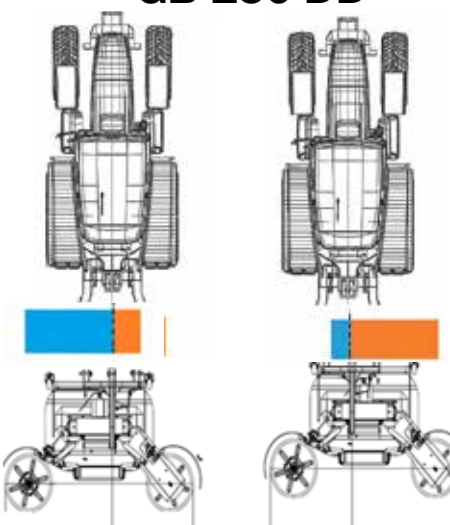

148 cm 114 cm 113 cm 149 cm

GB 180 DD

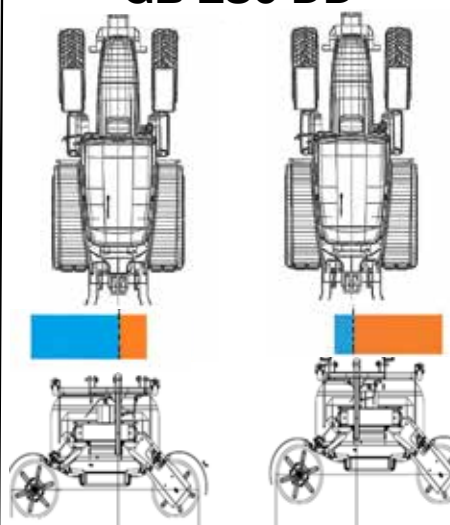

164 cm 129 cm 129 cm 164 cm

HPTO: 45 cm
 h1: 60 cm

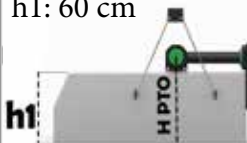
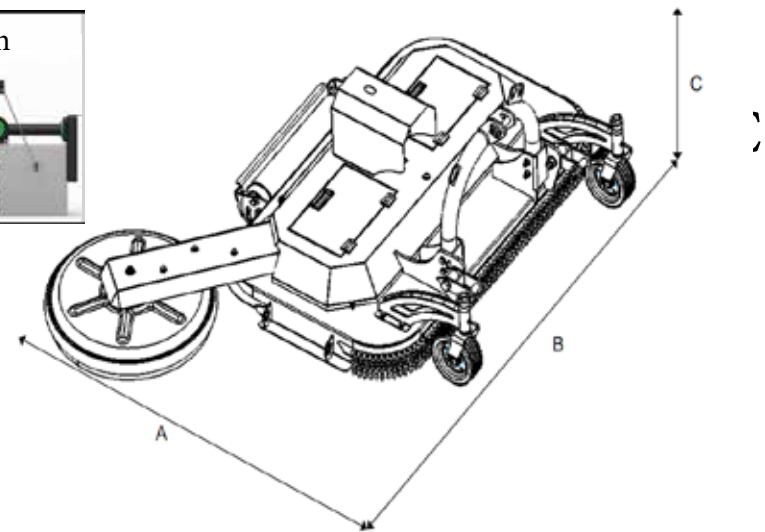
Mod.	Cod.	Larghezza lavoro (cm)	A (cm)	B (cm)	C (cm)	2 (mm)	HP/Kw	Kg	Lame
GB 150 DD	21.150HDD	150	159	263	26	65	30-80 / 22-59	433	6+2+2
GB 180 DD	21.180HDD	180	181	293	29	65	30-80 / 22-59	460	6+2+2



EMAIL

info@geo-agric.com

WEBSITE

www.geo-agric.com

PHONE

Tel. +39 0141877368